

HIGAIN REMOTE UNIT

Model	List Number	Part Number	CLEI Code
HRU-412	8A	150-1103-81	T1L2CCUAAA



**PAIRGAIN TECHNOLOGIES, INC.
ENGINEERING SERVICES TECHNICAL PRACTICE
SECTION 150-412-181-01**

Revision History of This Practice
Revision 01 - March 31, 1998
A) Initial Release

©Copyright 1998 PairGain Technologies, Inc.

PairGain, and HiGain are registered trademarks of PairGain Technologies, Inc.

Information contained in this document is company private to PairGain Technologies, Inc., and shall not be modified, used, copied, reproduced or disclosed in whole or in part without the written consent of PairGain.

Other product names mentioned in this practice are used for identification purposes only and may be trademarks or registered trademarks of their respective companies.

USING THIS TECHNICAL PRACTICE

Two types of messages, identified by icons, may appear in the text.



Notes contain information about special circumstances.



Cautions indicate the possibility of equipment damage or the possibility of personal injury.

TABLE OF CONTENTS

Overview	1
Applications.....	3
Specifications.....	4
Functional Description	5
Operational Capabilities	5
Front Panel Features	7
Rear Panel Features	10
Local and Line Powering	12
Installation	14
Unpack and Inspect the Shipment	14
Install the HRU-412 List 8A	14
Installation Test	16
Configure, Provision, and Monitor Performance.....	17
Connect an ASCII Terminal.....	17
Logging On and Using the Menus	19
View Span Status	21
Set Clock.....	23
System Settings	24
View Performance Data	25
View Performance History	26
View Alarm History.....	27
Loopbacks.....	29

Technical Support 32
 Warranty 32
 FCC Compliance..... 33
 UL Listing..... 34
 CSA Certification..... 34

LIST OF FIGURES

Figure 1. HRU-412 List 8A Block Diagram	6
Figure 2. HRU-412 List 8A Front Panel	7
Figure 3. HRU-412 List 8A Back Panel	10
Figure 4. HRU-412 List 8A Pin-Outs	15
Figure 5. HRU-412 List 8A RS-232 Wiring	18
Figure 6. Remote Log On Screen	20
Figure 7. Main Menu, Local Log On	20
Figure 8. Span Status Screen, No Doublers in Use	21
Figure 9. Span Status Screen, Doublers in Use	22
Figure 10. Set Clock Screen	23
Figure 11. System Settings Menu	24
Figure 12. Performance Data Screen	25
Figure 13. Performance History Screen	26
Figure 14. Alarm History Screen	27
Figure 15. HRU-412 List 8A Loopbacks	29

LIST OF TABLES

Table 1. HDSL Loss Over Cables	3
Table 2. HRU-412 List 8A Front Panel Components.....	8
Table 3. Rear Panel Components.....	11
Table 4. HRU-412 List 8A Alarm History Screen Definitions	28

OVERVIEW

The PairGain® HiGain® Remote Unit Model HRU-412 List 8A is the remote end of a repeaterless T1 transmission system. An HRU-412 List 8A connects to a HiGain Line Unit (HLU-231, HLU-232, HLU-319, or HLU-388), creating a HiGain system which provides 1.544 Mbps transmission on two unconditioned copper pairs over the full Carrier Serving Area (CSA) range. The CSA encompasses approximately 12,000 feet of AWG 24 wire or 9,000 feet of AWG 26 wire, including bridge taps and gauge changes. A HiGain system utilizes 2B1Q High-bit-rate Digital Subscriber Line (HDSL) transmission technology. The HRU-412 List 8A complies with ANSI T1E1.4, T1.403-1989, and T1E1.4/92-002R2 technical standards and recommendations. The HRU-412 List 8A mounts in a single slot of an industry standard 400 Mechanics type shelf. The system also complies with GR-63 Core of Network Equipment Building System (NEBS) Generic Equipment requirements, and Transport System Generic Requirements (TSGR) common requirements TR-TSY-000499.

The HRU-412 List 8A features:

- Customer Interface (CI)
- Front panel DS1 and HDSL LEDs
- Front panel loopback button
- Signature resistance on DS1 and HDSL ports
- Generic and addressable repeater Loopback activation codes
- Metallic Smart-Jack loopback (conforms to TR-TSY-000312)
- Provisioning switches for customer premise equipment (CPE) current, receive (RCV) level, and transmit loss of signal (TLOS) initiated loopback or alarm
- Line or local power options
- Sealing current
- Front panel jacks for test access
- RS-232 connector
- CPE current monitor test points
- Front panel HDSL margin threshold indicator for each loop

- Lightning and power cross protection on HDSL and DS1 interfaces
- 784kbps full-duplex 2B1Q HDSL transmission on two pairs
- DS0 blocking support

The HRU-412 List 8A supports PairGain's 1 x 1 Protection Switching System. The HRU-412 List 8A can be line powered or locally powered with a simplex sealing current option. The HDSL line input resistive signature is 14 ohms.



The HRU-412 List 8A supports PairGain's 1 x 1 Protection Switching System.

Applications

A HiGain system, consisting of a HiGain line unit and a HiGain remote unit, provides a quick and cost-effective way of delivering T1 High Capacity Digital Service (HCDS) to customers over copper pairs. The HiGain system can be deployed on two unconditioned, non-loaded copper pairs without repeaters, and without the need for bridged tap removal or binder group separation.

The general guidelines for HiGain system usage is that each loop have less than 35 dB of loss at 196 kHz, with 135 ohm driving and terminating impedances.

Table 1 provides a guide for the loss over various cable gauges at 196 kHz and 135 ohms. The table applies to the HDSL cable pairs between the HiGain line unit and the HiGain remote unit. Without specific loop insertion loss data, add 3 dB for each bridged tap and 1 dB for each cable gauge change.

The dc cable resistance determines the simplex powering resistance path of the loops. The maximum allowable resistance for a HiGain system is 800 ohms over two HDSL simplex loops. This means, for example, where 12 kft AWG 24 equals 34.08 dB (insertion loss), resistance is at 622 ohms which is well below the limit of 800 ohms.

Table 1. HDSL Loss Over Cables

Cable Gauge	Loss at 196 kHz (db/kft)	Ohms per kft
26/0.4mm	3.88	83
24/0.51mm	2.84	52
22/0.61mm	2.18	32
19/0.91mm	1.54	16

A HiGain system operates with a variety of other T1, POTS, Digital Data Service (DDS) equipment or other HiGain systems sharing the same cable binder group. HiGain systems provide temporary or permanent DS1 service and can provide a means of deploying service in advance of fiber-optic transmission systems.

SPECIFICATIONS

HDSL

Line Code	784 kbps 2B1Q full duplex
Output	+13 dB \pm 0.5 dB at 135 ohms
Line Impedance	135 ohms
Startup Time	15 seconds (typical), 60 seconds (maximum)

Maximum Provisioning Loss

35 dB at 196 kHz, 135 ohms

Line Clock Rate

Internal Stratum 4 clock

Power Consumption

5 Watts (typical), 7 Watts (maximum)

Electrical Protection

Secondary surge and power cross protection on all DS1 and HDSL ports

Environmental

Operating Temperature	- 40° C to + 65° C
Humidity	5 to 95% (non-condensing)

Mounting

Single wide 400 Mechanics type shelf

DS1

One-way Delay	< 220 microseconds per span
Line Impedance	100 ohms
Pulse Output	0 dB (RLEV = 0), -15 dB (RLEV = 15)
Input Level	> -22.5 dB
Line Rate	1.544 Mbps + 200 bps

Output Wander (MTIE and TVAR) Compliant with Section 7.2.1 of the T1X1.3/90-026R7 SONET committee report

Line Format AMI, B8ZS, or ZBTSI

Frame Format ESF, SF, or unframed

Dimensions

Height: 5.6 in. (14.22 cm)

Width: 1.4 in. (3.55 cm)

Depth: 5.6 in. (14.22 cm)

Weight 1 lb. 2 oz. (510.75 g)

FUNCTIONAL DESCRIPTION

This section describes the functions of the HRU-412 List 8A.

Operational Capabilities

HiGain utilizes PairGain's 2B1Q HDSL transceiver system to establish two full-duplex 784 kbps data channels between the HLU and a remotely mounted HRU-412 List 8A. This provides a total capacity of 1.568 Mbps between the two units. PairGain's HDSL technology provides full-duplex services at standard T1 rates over copper wires between an HLU and an HRU, which comprise one HiGain system.

The HRU-412 power supply converts the power feed voltage received on the simplex pairs (or the -48 Vdc input when locally powered) to voltages and currents required by the HRU-412 circuitry. The power supply generates +5, -5 and 30 Vdc outputs. The 30 Vdc output is converted to a 60 mA current feed to power a Network Interface Device (NID). Exercise caution when powering a unit that requires more than 30 Vdc. The HRU-412 List 8A cannot power a NID and another product simultaneously.

The HRU-412 dissipates 5 Watts of power and may consume up to 7 Watts when feeding 60 mA of simplex current to the CI.

The HRU-412 List 8A can be used with the HLU-232 line unit to form an automatic 1 x 1 protection switch system. For this application, the HRU-412 List 8A must be installed in the two slot HRE-422 remote enclosure. This enclosure provides access to the HRU-412 List 8A protection switch output, on pins 12 and 40, which control the protection switching function.

Figure 1 shows a block diagram of the HRU-412 List 8A.

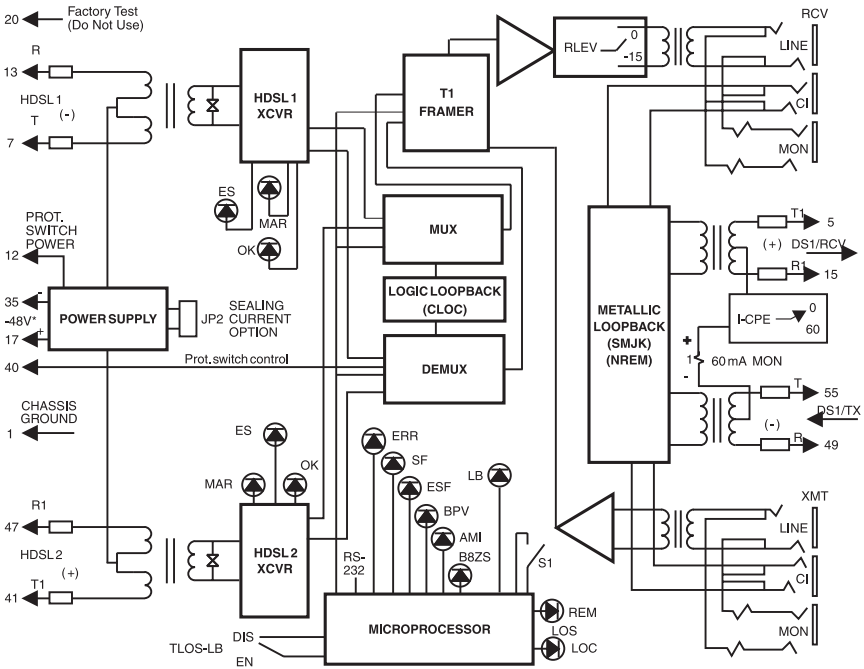

*-48 V power supply is required for local power applications

Figure 1. HRU-412 List 8A Block Diagram

Front Panel Features

Figure 2 shows the front view of the HRU-412 List 8A. Table 2 describes the HRU-412 List 8A front panel components.

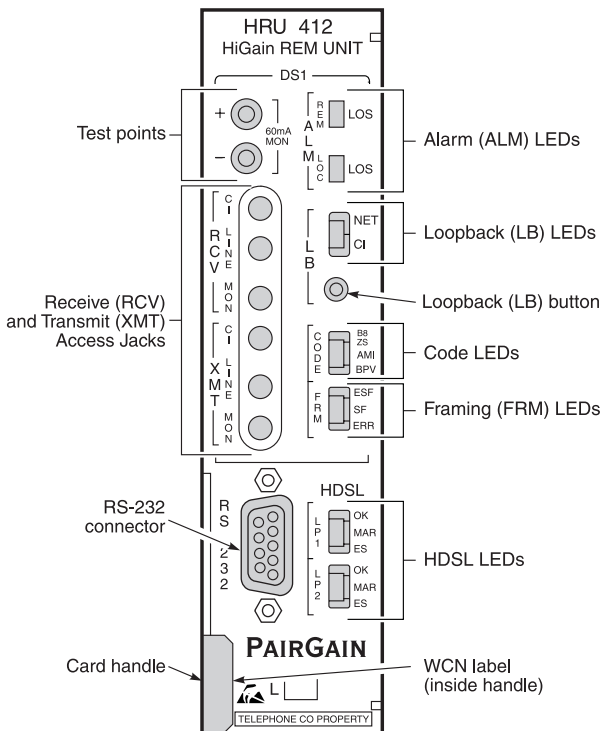

Figure 2. HRU-412 List 8A Front Panel

Table 2. HRU-412 List 8A Front Panel Components

Name	Function
Test points	Allow the 60 mA CPE current option to be measured. The current flowing is related to the voltage measured across the + and - test points by the following relationship: CPE CURRENT = 1 MA/1 MV. Typical readings range from 55 to 65 mV, which equate to a 55 to 65 mA current range.
Receive (RCV) and transmit (XMT) jacks	Provide splitting and monitor access to the CPE DS1 interface. The jacks are transformer isolated from the CPE DS1 metallic interface.
Alarm LEDs	REM LOS LED lights red to indicate a loss of signal (LOS) at the T1 input to the HLU. This LOS condition causes the HRU-412 List 8A to transmit the alarm indicating signal (AIS) pattern toward the CPE. LOC LOS LED lights red to indicate a loss of signal (LOS) at the T1 input to the HRU-412 List 8A. This LOS condition transmits the AIS pattern toward the DSX-1 (TLOS Disabled) or to execute a logic loopback in the HRU-412 List 8A (TLOS Enabled).
Loopback (LB) LEDs	NET LED lights green to indicate the HRU-412 List 8A is in a loopback state where the signal from the network is looping back to the network. CIS LED lights yellow to indicate the HRU-412 List 8A is in a loopback state in which the signal from the customer interface (CI) is looping back to the CI.
Code LEDs	B8ZS LED lights green to indicate that the user DS1 code option is set to B8ZS. AMI LED lights yellow to indicate that the user DS1 code option is set to AMI. BPV LED lights red to indicate that the user DS1 code option is set to BPV. If the user DS1 code option is set to AUTO, the lit LED indicates what DS1 signal is being received. Note that these settings are made on the HLU.
Framing LEDs	ESF LED lights green to indicate that the framing pattern of the received signal is Extended Super Frame (ESF). SF LED lights yellow to indicate that the framing pattern of the received signal is Super Frame (SF). ERR LED lights red to indicate that a DS1 frame error has occurred. No frame LED lights when the HRU-412 List 8A input pattern is unframed or when the framing option is set to UNFR (unframed). Note that this settings is made on the HLU.

Table 2. HRU-412 List 8A Front Panel Components (Cont.)

HDSL LEDs	<p>LP1 OK LED flashes green while HDSL Loop 1 is synchronizing with the HLU. The LED lights green to indicate that loop 1 is properly synchronized with the HLU.</p> <p>LP1 MAR LED lights yellow when the HRU-412 List 8A margin on HDSL loop 1 has dropped below the user-defined margin threshold value. This indicator flashes yellow at a slow rate to indicate that a loss of sync word (LOSW) exists in span 1, loop 1 of the HDSL pair between the HLU and the doubler. This indicator flashes yellow at a rapid rate to indicate that a LOSW problem exists in span 2, loop 1 of the HDSL pairs between the first and second doublers.</p> <p>LP1 ES LED flashes red every second that a CRC error is detected on loop 1 from the upstream module.</p> <p>LP2 OK LED flashes green while HDSL Loop 1 is synchronizing with the HLU. The LED lights green to indicate that loop 2 is properly synchronized with the HLU.</p> <p>LP2 MAR LED lights yellow when the HRU-412 List 8A margin on HDSL loop 2 has dropped below the user-defined margin threshold value. This indicator flashes yellow at a slow rate to indicate that a loss of sync word (LOSW) exists in span 1, loop 2 of the HDSL pair between the HLU and the doubler. This indicator flashes yellow at a rapid rate to indicate that a LOSW problem exists in span 2, loop 2 of the HDSL pairs between the first and second doublers.</p> <p>LP2 ES LED flashes red every second that a CRC error is detected on loop 2 from the upstream module.</p>
RS-232 (Craft) connector	Provides a connection port for an ASCII terminal. The ASCII terminal allows access to the maintenance, provisioning, and performance monitoring menus and screens.
Card handle	Pull on the card handle to remove the HRU-412 List 8A from the shelf slot.
WCN label	Provides the warranty control number for the HRU-412 List 8A.

Rear Panel Features

The HRU-412 List 8A back panel features are shown in Figure 3. Table 3 describes the features.

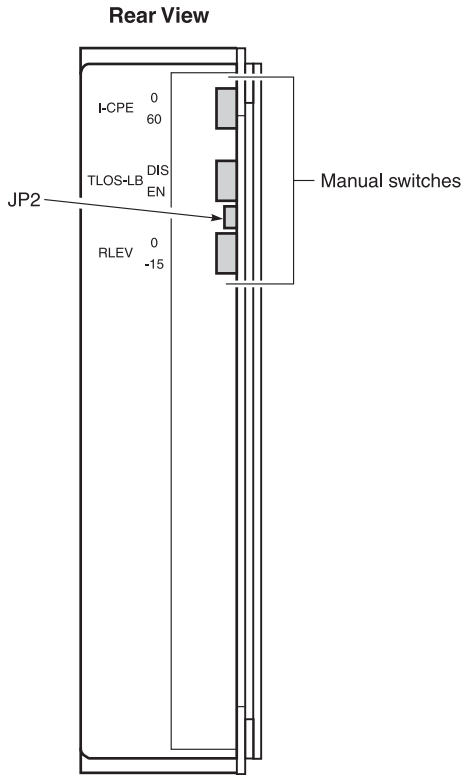

Figure 3. HRU-412 List 8A Back Panel

Table 3. Rear Panel Components

Switch	Setting	Function
I-CPE	0	Sets the CPE current to 0 mA.
	60	Sets the CPE current to 60 mA to power an external NID.
 <p>The CPE current control signals terminate on pins 32 and 34 of the card-edge converter. These access pins are for factory test only and are not used. Single slot remote enclosures and seven slot enclosures use the pins to control the CPE options in older HRU units. These enclosures must be optimized for 0 mA current to prevent a conflict between external connections to pins 32 and 34 and the settings of the I-CPE switch.</p>		
TLOS-LB	DIS	Does not allow the HRU-412 List 8A to enter its logic loopback state when a loss of the T1 XMT signal from the CPE causes the HLU to transmit the AIS signal toward the DSX-1.
	EN	Allows the HRU-412 List 8A to enter its logic loopback state when a loss of the T1 XMT signal from the CPE causes the HLU to transmit the AIS signal toward the DSX-1. While in this loopback state, the HRU-412 List 8A transmits the AIS signal toward the CPE and returns the network signal back to the network. The HLU displays TLOS in its front panel display. This condition remains until a valid T1 signal is received from the CPE or until the 3-in-5 in-band loopdown command is issued. Once the TLOS initiated loopback occurs, it will not reoccur until the CPE T1 signal has been reapplied and then removed. This feature prevents the HRU-412 List 8A from oscillating into and out of TLOS loopback when a loopdown command is issued in the absence of a T1 signal from the CPE. This TLOS option must never be enabled when the HRU-412 List 8A is used with old line units that do not support this feature. These older line units (List 6 and under) cannot loopdown an HRU-412 List 8A that is in a TLOS loop-up state when they receive the 3-in-5 in-band loopdown command.
RLEV	0	Configures the T1 RCV level to 0 dB. This sets the T1 output signal level from the HRU-412 List 8A toward the NI to 0 dB. Use this setting when the HRU-412 List 8A is not functioning as a NID but is connected to an external NID. It allows the external NID to set the appropriate NI level.
	15	Configures the T1 RCV level to -15 dB. This sets the T1 output signal level from the HRU-412 List 8A toward the NI level to -15 dB. This setting is recommended when the HRU-412 List 8A functions as a NID.

Table 3. Rear Panel Components (Cont.)

JP2	Allows the enabling or disabling of the sealing current. To enable, connect JP2 across both terminals. To disable (default), remove the jumper from the inner terminal and leave it attached to the outer terminal only.
-----	--

Local and Line Powering

The HRU-412 List 8A unit can be line powered or local powered. It always chooses the local -48 Vdc power source, if present. It defaults to line power only in the absence of local power. Some older HLU automatically turn off their line powering when connected to the HRU-412 List 8A. The older versions of the HLU-231 (Lists 1, 2, 3, 3A, and 4) must have their PWRF user option disabled for them to work properly with a locally powered HRU-412 List 8A. Refer to the appropriate HLU technical practice if you need more information about its local and line powering capabilities.

When locally powered, the HRU-412 List 8A provides 15 mA (short loop) to 10 mA (long loop) simplex sealing current toward all versions of the HLU over the two HDSL pairs. JP2, shown in Figure 3, allows the sealing current to be enabled or disabled. To enable the sealing current, connect JP2 across both terminals. To disable the sealing current, remove the jumper from the inner terminal and attach it to the outer terminal. The factory default setting is disabled. This simplex sealing current is polarity sensitive and will not flow if the HDSL loops at the HRU-412 List 8A are reversed. Reversed loops are indicated by a CHREV message in the ALARMS line of the Span Status screen.

The simplex sealing current is not compatible with doublers HDU-451 List 1, 2, or 3. These doublers block the flow of simplex sealing current. To allow the flow of sealing current, use doublers HDU-451 List 4, HDU-439, HDU-437, or HDU-409 with the HRU-412 List 8A.

If local power is lost to an HRU-412 List 8A, the last span loses sync. When the HLU or HDU attempts to reestablish sync, it detects that the HRU-412 List 8A is not locally powered and applies line power to it. The HRU-412 List 8A then powers up and operates normally if the HRU-412 List 8A is within range to support line powering.

The -48 Vdc local power supply must have a 105 mA output current capacity (5 W) to power each HRU-412 List 8A when the I-CPE option is set to 0 mA. The -48 Vdc local power supply must have a 145 mA output current capacity (7 W) to power each HRU-412 List 8A when the I-CPE option is set to 60 mA.

A Teltrend WPS-2005 Wall-Mount Power Supply, or equivalent, is capable of powering two HRU-412 List 8A units with the I-CPE option switch set to 0 mA or one HRU-412 List 8A with the I-CPE option switch set to 60 mA.

The HRU-412 List 8A can be used in limited (2000 ohms) and unlimited (full CSA) three span line powering applications. The line units and doublers compatible with limited and unlimited line powering are shown below:

1 Limited: loop resistance < 2000 ohms

- Line units: HLU-231 List 7D and 7B; HLU-431 List 1D; HLU-231 List 8, 8D, and 8E; HLU 319 List 5, 5D, and 5E; HLU-388 List 5 and 5D
- Doublers: HDU-437 List 1 and 1B; HDU-439 List 1 and 1B
- Doublers: HDU-409; HDU-407; HDU-406

2 Unlimited: full CSA range on all spans

- Line units: HLU-231 List 8, 8D and 8E; HLU 319 List 5, 5D, and 5E; HLU-388 List 5 and 5D
- Doublers: HDU-409; HDU-407; HDU-406



The HRU-412 List 8A supports up to three spans (with the use of two doublers).

For more information on doublers, see the technical practices for the HiGain Mini Doublers and the HiGain Micro Doubler.

INSTALLATION

This section describes how to install the HRU-412 List 8A.

Unpack and Inspect the Shipment

Upon receipt of the equipment:

- 1 Unpack the container and visually inspect the product for signs of damage. If the equipment has been damaged in transit, immediately report the extent of the damage to the transportation company and to your sales representative.
- 2 Verify the contents using the packing list to ensure complete and accurate shipment.

If you must store the equipment for a prolonged period, store it in the original container.

Install the HRU-412 List 8A

The HRU-412 List 8A mounts in the following shelves (indoor use):

- PairGain's HRE-421 (double-width, single-mount)
- HRE-422 (double-wide, double mount)
- HRE-424 (double-wide, four-unit wall mount)
- HRE-420 (single-wide, single mount)
- HRE-427 (seven-unit wall or rack mount)
- HRE-425 (12 slot wall or rack mount)

For outdoor applications, the HRU-412 List 8A mounts in the following shelves:

- HRE-454 (four-unit)
- HRE-450 (single-unit)
- 400 Mechanics type shelves

The HRU-412 List 8A pin-outs are shown in Figure 4. The active pins are shown in black.

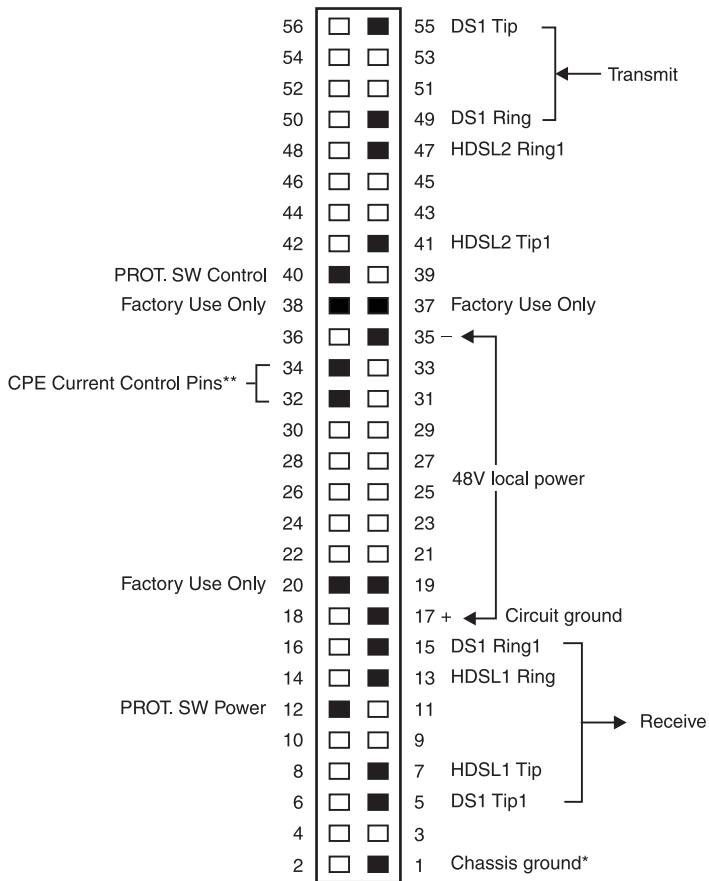

* Chassis Ground may be tied to Earth Ground per local practice.
 Note: Active pins are highlighted in black.

Figure 4. HRU-412 List 8A Pin-Outs

To install the HRU-412 List 8A:

- 1 Ensure that the shelf is correctly mounted and wired (refer to the shelf's technical practice for additional information).
- 2 Slide the HRU-412 List 8A into the card guides for the desired slot, then push the unit back until it touches the backplane card-edge connectors.
- 3 Place your thumbs on the HRU-412 List 8A front panel and push the HRU-412 List 8A into the card-edge connector until it is secured in the card guides.

Installation Test

Perform the following procedure to test the HRU-412 List 8A.

- 1 Press the loopback button (see Figure 2 for the location of this button) for at least five seconds.

Verify that the LB NET LED lights green, indicating that the HRU-412 List 8A is in a digital (NREM) loopback state. If possible, verify that the HLU front panel displays NREM.

- 2 Have the CO transmit a T1 test signal to the HLU.

Measure the return (loop) signal to verify it is error free. If the signal is not error free, remove the HRU-412 List 8A from loopback by pressing the loopback button for five seconds. The LB NET LED should be off.

- 3 Have the CO send the HLU 4-in-7 in-band loop-up (NLOC) for five seconds.

If possible, verify that the HLU front panel displays NLOC.

- 4 Repeat step 2.

If the test passes, a problem exists in the cable pair or in the HRU-412 List 8A. If the test fails, the problem is at the CO.

- 5 Check that the proper ports are in use for the HDSL and DS1 pair by using an ohm-meter to verify that the HDSL ports have a 180k transmit to receive resistive signature and that the DS1 ports have a 15 ohm transmit to receive resistive signature.

Measure the return (loop) signal to verify it is error free.

- 6 If using an external NID, set the I-CPE switch (located on the back panel of the HRU-412 List 8A; see Figure 3) to 60 mA and verify the NID is under power. Check that the voltage across the front panel test points (60 mA MON) measure between 55 mV and 65 mV.
- 7 Enable the sealing current option (JP2 connected). Use a milli-amp meter to verify transmit or receive current in either HDSL pair.

CONFIGURE, PROVISION, AND MONITOR PERFORMANCE

The following sections describe how to perform configuration, provisioning and performance monitoring functions using the HRU-412 List 8A menus and screens.

Connect an ASCII Terminal

Connect an ASCII terminal:

- 1 Connect a standard 9-pin serial terminal cable to the Craft port (RS-232 connector), an DB-9 female connector, on the HRU-412 List 8A. See Figure 5 for the DB-9 female connector wiring.

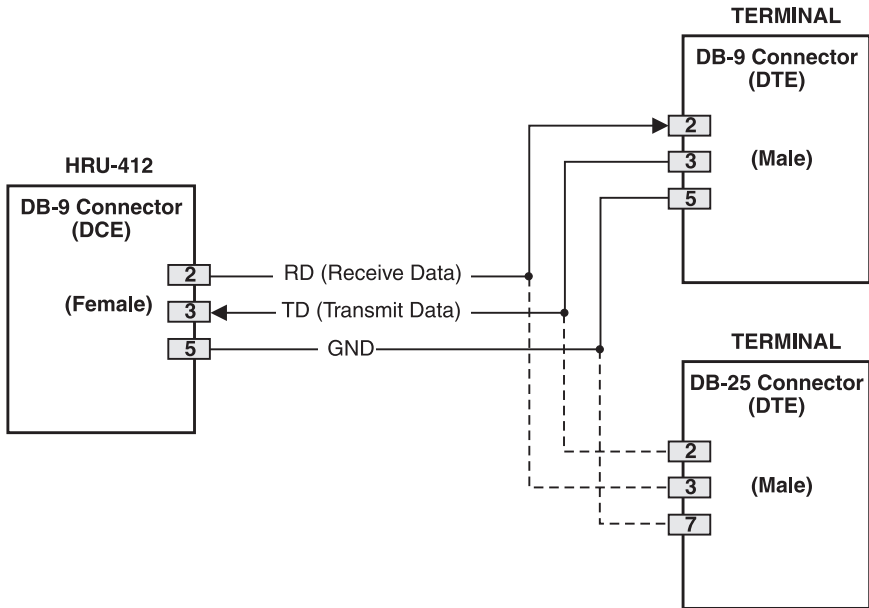

Figure 5. HRU-412 List 8A Craft (RS-232) Wiring

- 2 Connect the other end of the terminal cable to the console port on the ASCII terminal.
- 3 Configure the ASCII terminal to the following communication settings:
 - 1200 to 9600 baud
 - no parity
 - 8 data bits
 - 1 stop bit
 - hardware flow control to OFF

Logging On and Using the Menus

The HRU-412 List 8A supports local and remote log on. Local log on connects the Craft port (RS-232 connector) to the HRU-412 List 8A internal database. Remote log on connects the HRU-412 List 8A to the HLU using the HDSL Embedded Operation Channel (EOC) as the data link between the two units. Remote log on creates menus and screens at the HRU-412 List 8A that are identical to those at the HLU. See the appropriate line unit technical practice for more information about the menus and screens.

Initial log on to the HRU-412 List 8A is local for non-doubler applications. When the HRU-412 List 8A is not connected to an HLU, the displayed menus and screens are those from the HRU-412 List 8A internal database.

When the HRU-412 List 8A is connected to an HLU and doublers are in use, the port interface resets to remote when the two units synchornize. The remote log off option on the Main Menu (shown when in remote mode only) allows the termination of a remote session. Terminating a remote log on allows other units (such as a doubler) to log on through the Craft port. Terminating each remote session before beginning another is necessary because a HiGain circuit can support the log on of only one unit at a time. An active session for any unit prevents simultaneous sessions for any other circuit.

This section shows you how to log on and access the menus and screens using the ASCII terminal.

- 1 Press the spacebar several times to activate the autobaud feature and to display the logon screen. When using doublers, the remote log on screen displays when the HRU-412 List 8A and the HLU synchronize. See [Figure 6](#).

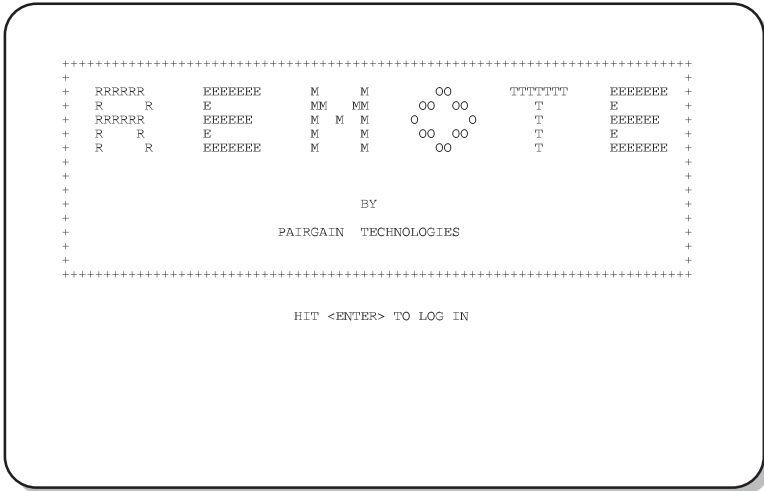

Figure 6. Remote Log On Screen

- 2 Press **ENTER**. The Main Menu displays.

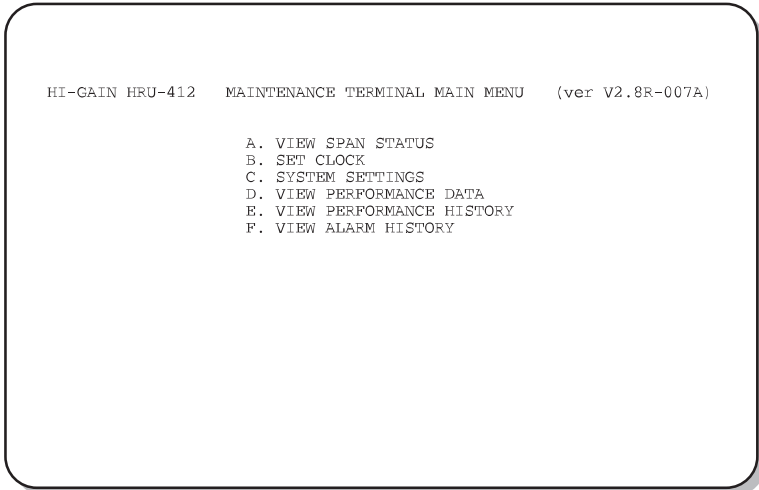

Figure 7. Main Menu, Local Log On

Access options available on the Main Menu by typing the desired letter and then pressing **ENTER**.

View Span Status

From the Main Menu, type **A**. The Span Status screen displays.

When no doublers are in use, the following Span Status screen displays:

```

                                SPAN STATUS
                                (HLU/ver0.0-0000:HRU/ver2.8-007A)
TIME: 08:29:25
DATE: 06/25/97

ALARMS: NONE
LOOPBACK: OFF

                                HLU                                HRU
                                HDSL-1 HDSL-2 HDSL-1 HDSL-2
                                cur/min/max cur/min/max cur/min/max cur/min/max
MARGIN:                        N/A      N/A      N/A      N/A      dB
PULSE ATTN:                    N/A      N/A      N/A      N/A      dB
PPM OFFSET:                    N/A      N/A      N/A      N/A      ppm
24 HOUR ES:                    00001  00002  00001  00001  seconds
24 HOUR UAS:                   00000  00000  01073  01070  seconds

                                DS1 STATUS
                                HLU                                HRU
24 HOUR BPV Seconds:          00001  00000
24 HOUR UAS Count:           00000  00000
Frame type:                  N/A      Unframed
Code type:                   N/A      B8ZS

                                (E)xit (U)pdate

```

Figure 8. Span Status Screen, No Doublers in Use

- 1 Type **U** to update the screen.
- 2 Type **E** to exit to the Main Menu.

When doublers are in use, the following Span Status screen displays:

```

                                SPAN 1 STATUS
                                ( HLU/ver2.2-002D:HDU1/ver2.7-0004)

TIME: 08:41:01
DATE: 06/25/97                                CIRCUIT ID#: PairGain2

ALARMS: NONE
LOOPBACK: OFF

                                HLU
                                HDU1
                                HDU1
                                HDU1
                                HDU1
MARGIN:      HDSL-1   HDSL-2   HDSL-1   HDSL-2
              cur/min/max cur/min/max cur/min/max cur/min/max
              20/17/21   21/18/21   21/00/22   21/00/22   dB
PULSE ATTN:      00         00         00         00
PPM OFFSET:      00         00         06         06
24 HOUR ES:      00001     00002     00001     00002
seconds
24 HOUR UAS:      00792     00791     00013     00012
seconds

                                DS1 STATUS
                                HLU           HRU
24 HOUR BPV Seconds:      00058           00241
24 HOUR UAS Count:       00013           00009
Frame type:              Unframed         Unframed
Code type:                AMI             AMI

                                (E)xit (U)pdate (S)pan

```

Figure 9. Span Status Screen, Doublers in Use

Do any of the following:

- Type **S** to view the next span.
- Type **U** to update the screen.
- Type **E** to exit.

Set Clock

This option is available during Local log on only.

- 1 From the Main Menu, type **B** to display the Set Clock menu.

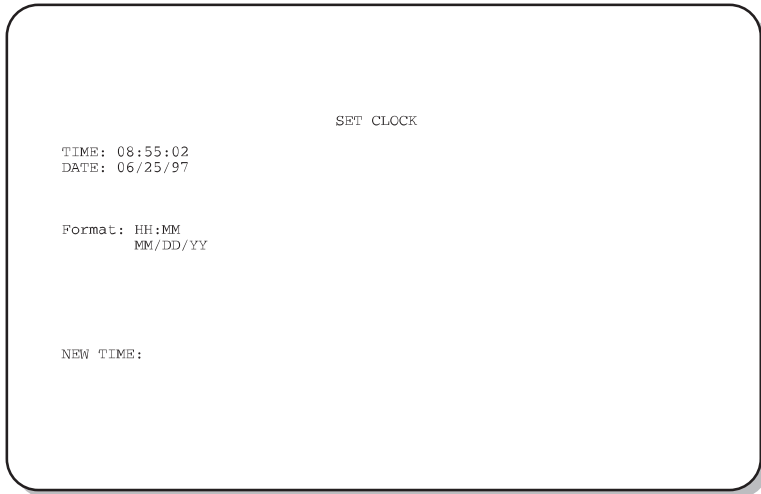

Figure 10. Set Clock Screen

- 2 Enter the time (in 24 hour format) at the Time prompt.
- 3 Press **ENTER**.
- 4 Enter the date (mm/dd/yy) at the Date prompt.
- 5 Press **ENTER**.
- 6 Type **E** to exit the Set Clock menu.

System Settings

- 1 From the Main Menu, type **C** to display the System Settings menu.

```

                                SYSTEM SETTINGS

TIME: 08:57:36
DATE: 06/25/97                                CIRCUIT ID#: PairGain2

EQUALIZATION:      399
SMART-JACK LB:    ENABLE
SPECIAL LPBK:    GNLB
POWER:            ENABLE
ZETSI:           OFF
ES ALARM THRES:  NONE
LOOPBACK TIMEOUT: 20
ALARM:            DISABLE
DSL LINE CODE:   AUTO
FRAMING:          AUTO
AIS ON HDSL LOSW: 2 LOOPS
AIS ON SMJK/NREM: ENABLE
MARGIN ALM THRES: 15
DSO BLOCKING: xx - Blocked Channels
01 02 03 04 05 06 07 08 09 10 11 12 13 14 15 16 17 18 19 20 21 22 23
24

                                (B)xit

```

Figure 11. System Settings Menu

- 2 View the HRU-412 List 8A system settings. Change system settings at the HLU connected to the HRU-412 List 8A.

View Performance Data

- 1 From the Main Menu, type **D** to display the Performance Data screen.

```

Date: 06/25/97          SPAN 3 PERFORMANCE DATA
CIRCUIT ID#: PairGain2
                ERRORLED SECONDS/UNAVAILABLE SECONDS

                DS1                HDSL-1                HDSL-2
                HLU                HRU                HDU2                HRU                HDU2                HRU
05:15          000/000          000/000          000/000          000/000          000/000          000/000
05:30          000/000          233/001          002/005          002/001          003/007          003/002
05:45          000/000          000/000          000/000          000/000          000/000          000/000
06:00          000/000          000/000          000/000          000/000          000/000          000/000
06:15          000/000          000/000          000/000          000/000          000/000          000/000
06:30          000/000          000/000          000/000          000/000          000/000          000/000
06:45          000/000          000/000          000/000          000/000          000/000          000/000
07:00          000/000          000/000          000/000          000/000          000/000          000/000
07:15          000/000          000/000          000/000          000/000          000/000          000/000
07:30          000/000          000/000          000/000          000/000          000/000          000/000
07:45          000/000          002/002          001/009          003/003          002/006          002/000
08:00          000/000          000/000          000/000          000/000          000/000          000/000
08:15          004/004          000/000          000/000          001/008          000/000          001/008
08:30          033/006          000/000          000/000          000/061          000/000          000/060
08:45          021/003          006/006          000/011          003/041          003/009          005/038
09:00          004/002          000/000          000/000          001/007          000/000          001/007

                (E)xit (P)revious (N)ext (S)pan

```

Figure 12. Performance Data Screen

- 2 If spans are in use, do any of the following:
 - type **S** to view them
 - type **P** to view a previous span
 - type **N** to view the next span
- 3 Type **E** to exit the Performance Data screen.

View Alarm History

- 1 From the Main Menu, type **F** to display the Alarm History screen.

```

                                ALARM HISTORY
TIME: 09:20:33
DATE: 06/25/97
CIRCUIT ID#: PairGain2

Type           First           Last           Current       Count
LOS, DS1-HLU           OK             OK             OK             000
LOS, DS1-HRU           OK             OK             OK             000
SPAN3 LOSW, HDSL1 06/25/97-08:37  06/25/97-09:17  OK             004
SPAN3 LOSW, HDSL2 06/25/97-08:37  06/25/97-09:17  OK             006
SPAN3 ES, HDSL1        OK             OK             OK             000
SPAN3 ES, HDSL2        OK             OK             OK             000
SPAN3 MARGIN L1       06/25/97-09:00  06/25/97-09:18  OK             003
SPAN3 MARGIN L2       06/25/97-08:38  06/25/97-09:18  OK             004
PWR-OPEN              06/25/97-08:31  06/25/97-09:17  OK             013
PWR-SHRT              06/25/97-08:58  06/25/97-09:17  OK             003

LAST CLEARED: 06/25/97-08:31

(E)xit (U)pdate (S)pan

```

Figure 14. Alarm History Screen

- 2 Type **U** to update the Alarm History screen to the most current data.
- 3 If spans are in use, type **S** to view them.
- 4 Type **E** to exit the Alarm History screen.

Table 4 lists the HRU-412 List 8A alarm types and descriptions.

Table 4. HRU-412 List 8A Alarm History Screen Definitions

Message	Full Name	Description
NONE	No Alarms	No active alarms, or alarms previously detected are no longer active or have been reset.
LLOS	Local Loss of Signal	No signal from local T1 interface.
RLOS	Remote Loss of Signal	No signal from remote T1 interface.
LOSW	Loss of Sync Word	One of the HDSL loops has lost sync.
H1ES	HDSL Loop 1 Errored Second	Loop 1 CRC exceeds the ES threshold set at the HLU.
H2ES	HDSL Loop 2 Errored Second	Loop 2 CRC exceeds the ES threshold set at the HLU.
DS1	Digital Service 1	BPVs exceed the ES threshold set at the HLU.
ACO	Alarm Cut Off	An Alarm Cut Off is in effect.
SMJK	Smart-Jack loopback	Loopback at HRU-412 List 8A toward the network initiated by 2-in-5 in-band loopback code or out-of-band ESF data link code FF48.
NREM	Network Remote Loopback	Loopback at HRU-412 List 8A toward the network initiated at CO by intelligent line repeater code, by HLU front panel pushbutton, or using HLU maintenance terminal.
NLOC	Network Local Loopback	Loopback at HLU toward the network initiated at CO by intelligent office repeater code or by HLU front panel pushbutton.
LAIS	Local Alarm Indicating Signal	Indicates an AIS pattern (all 1s) is transmitting from the local T1 output port.
RAIS	Remote Alarm Indicating Signal	Indicates an AIS pattern (all 1s) is transmitting from the remote T1 output port.

LOOPBACKS

The HRU-412 List 8A supports 6 types of loopbacks (see [Figure 15](#)).

- TLOS (transmit loss of signal)
- CREM (customer remote loopback)
- NREM (network remote loopback)
- NLOC (network local loopback)
- CLOC (customer local loopback)
- SMJK (Smart-Jack)

Loopback tests initiate at the CO, using in-band commands.

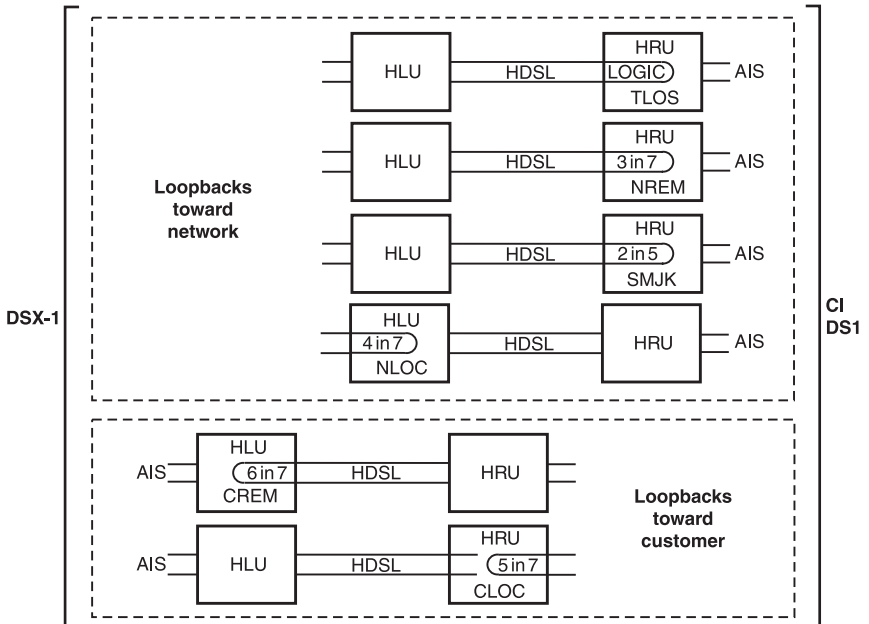

Figure 15. HRU-412 List 8A Loopbacks

A Smart-Jack loopback causes the T1 interface chip to transmit the AIS pattern to the NI and back to the HRU-412 List 8A T1 receiver circuit. The T1 input to the HRU-412 List 8A at the XMT port is disconnected and terminated in 100 ohms. The AIS pattern is examined by the HRU-412 List 8A for its overall integrity. The Smart-Jack loopback lasts about 100 milliseconds and terminates in one of the following conditions:

- 1 Pre-loop failed: if the transmit and receive patterns (all 1s) do not match, there is a problem in the HRU-412 List 8A. The HLU declares an HRU pre-loopback fail condition. This terminates the loopback test and returns the HRU-412 List 8A to its unlooped normal state, indicating a defective HRU-412 List 8A at the HLU.
- 2 Pre-loop passed: if the transmit and receive patterns do match, an HRU pre-loopback pass condition is declared. All active circuits are working. The metallic loopback relay remains closed and a logic loopback within the HRU-412 List 8A is enabled.

Logic loopback is required in order to present the all 1s pattern to the CI and at the same time to loop the signal received from the network back toward the network. The HiGain system is in the AIS/ENA Smart-Jack loopback state. It remains in this state until a loopdown command is detected or the default time out period (if enabled at the HLU) expires.

When the HRU-412 List 8A is in the AIS/ENA Smart-Jack metallic loopback state, the T1 input LOS, Code, and Frame monitoring circuits are connected to the unframed AIS pattern, which is being looped back to these circuits through the loopback relay. The CPE input signal is no longer monitored, since the input circuit is open and terminates in 100 ohms. This forces the FRM LED off and the LOC LOS LED off. The CODE LED indicates AMI if the HLU CODE option is set to AUTO or AMI. It indicates B8ZS if the CODE option is set to B8ZS. The AIS/ENA metallic loopback scenario tests all of the HiGain system's active circuits and fully conforms to TR-TSY-000312.

When the HRU-412 List 8A is in an AIS/DIS Smart-Jack metallic loopback state, the T1 input LOS, Code, and Frame monitoring circuits are connected to the network signal, which is being looped back to these circuits through the loopback relay. The CPE input signal is no longer being monitored, since the input circuit was opened and terminated in 100 ohms. The FRM and LOC LOS LEDs indicate the status of this signal from the network. The CODE LED indicates the code (AMI or B8ZS) if the CODE option is set to AUTO. It indicates AMI or B8ZS if the CODE option is set to AMI or B8ZS, respectively.

All HRU-412 List 8A loopbacks toward the network (NREM and SMJK) are metallic/logic (AIS/ENA) or metallic only (AIS/DIS). The TLOS loopback is a logic loopback.

The SMJK and NREM loopbacks perform the same functions; their initiation differs. The SMJK identifying label indicates that the loopback was initiated by the 2-in-5 in-band command. NREM initiates by any in-band command except the 2-in-5 command. These other in-band commands include 3-in-7 command, 16-bit addressable repeater commands, or activation using the front panel MODE and SEL buttons.



When T1 loopback tests are made on the HiGain system with external metallic loopback connections at either end, the DS1 code at the metallic loopback interface may be different from the DS1 code at the opposite end when the DS1 user option is set to AUTO. For example, if the HRU-412 List 8A has a metallic loopback and the HLU receive pattern code is changed from AMI to B8ZS, an all 0s pattern is sent to the HLU. The HRU-412 List 8A remains in AMI mode and loops all 0s causing the HRU-412 List 8A to indicate an LOS condition. The result is that the HLU outputs an AIS pattern.

TECHNICAL SUPPORT

PairGain Technical Assistance is available 24 hours a day, 7 days a week by contacting PairGain Customer Service Engineering group at:

Telephone: (800) 638-0031 or (714) 832-9922

Fax: (714) 832-9924

During normal business hours (8:00 AM to 5:00 PM, Pacific Time, Monday to Friday, excluding holidays), technical assistance calls are usually answered directly by a Customer Service Engineer. Sometimes a request for technical assistance is handled by an on-duty Customer Service Engineer through a callback process. This process generally results in a callback within 30 minutes of initiating the request.

In addition, PairGain maintains a computer bulletin board system to obtain current information on PairGain products, product troubleshooting tips and aids, access to helpful utilities, and to post requests or questions. This system is available 24 hours a day by calling (714) 730-3299. Transmission speeds up to 28.8 kbps are supported with a character format of 8-N-1.

Warranty

PairGain Technologies warrants this product to be free of defects and to be fully functional for a period of 60 months from the date of original shipment, given correct customer installation and regular maintenance. PairGain will repair or replace any unit without cost during this period if the unit is found to be defective for any reason other than abuse or incorrect use or installation.

Do not try to repair the unit. If it fails, replace it with another unit and return the faulty unit to PairGain for repair. Any modifications to the unit by anyone other than an authorized PairGain representative voids the warranty.

If a unit needs repair, call PairGain for a Return Material Authorization (RMA) number and return the defective unit, freight prepaid, along with a brief description of the problem, to:

PairGain Technologies, Inc.
14352 Franklin Avenue
Tustin, CA 92780
ATTN: Repair and Return Dept.
(800) 638-0031

PairGain continues to repair faulty modules beyond the warranty program at a nominal charge. Contact your PairGain sales representative for details and pricing.

FCC Compliance

This unit complies with the limits for a Class A digital device, pursuant to Part 15 of the FCC rules. These limits are designed to provide reasonable protection against harmful interference in a residential installation. This equipment generates, uses and can radiate radio frequency energy and, if not installed and used in accordance with the instructions, may cause harmful interference to radio communications. However, there is no guarantee that interference will not occur in a particular installation. If this equipment does cause harmful interference to radio or television reception, which can be determined by turning the equipment off and on, the user is encouraged to try to correct the situation by one or more of the following measures:

- Reorient or relocate the receiving antenna.
- Increase the separation between the equipment and the receiver.
- Consult the dealer or an experienced radio or television technician for help.

UL Listing

The HRU-412 List 8A is UL listed. Use caution when installing or modifying telephone lines. Dangerous voltages may be present. Do not install telephone wiring during a lightning storm. Always disconnect telephone lines and power connections from wall outlets before servicing or disassembling this equipment.

CSA Certification

The HRU-412 List 8A has been tested and found to comply with CSA Standard C22.2-950 with telecommunication features.

All wiring external to the product(s) should follow the provisions of the current edition of the National Electrical Code.

Corporate Office

14402 Franklin Avenue
Tustin, CA 92780

Tel: (714) 832-9922

Fax: (714) 832-9924

For Technical Assistance:

(800) 638-0031

