

# USER MANUAL

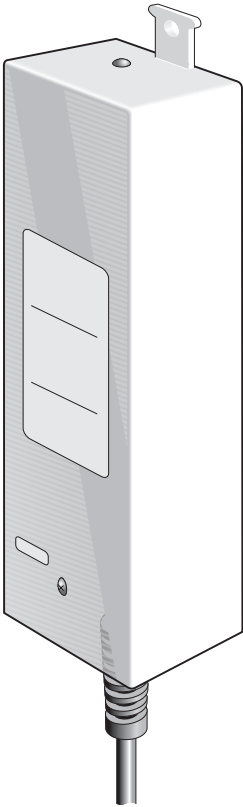

**HRE-500 List 1**  
**HiGain Remote Enclosure**  
Product Catalog: HRE-500-L1  
CLEI: T1R4EGDC



## Revision History

Revision	Release Date	Revisions Made
01	March 27, 1998	Initial release of document
02	June 16, 1998	<ul style="list-style-type: none"> <li>• Changed stub description</li> <li>• Added internal HRE-500 description</li> <li>• Added grounding information</li> <li>• Changed illustrations 1, 2, 3, 4, 6</li> </ul>
03	April 15, 1999	Changed from 6-pair to 4-pair stub
04	September 24, 1999	Enhanced standards compliances
05	July 25, 2002	Rebranding-no technical changes

### Copyright

July 25, 2002

© 2002 ADC DSL Systems, Inc. All rights reserved.

### Trademark Information

*ADC is a registered trademark of ADC Telecommunications, Inc. HiGain is a registered trademark of ADC DSL Systems, Inc. No right, license, or interest to such trademarks is granted hereunder, and you agree that no such right, license, or interest shall be asserted by you with respect to such trademark. Other product names mentioned in this practice are used for identification purposes only and may be trademarks or registered trademarks of their respective companies.*

### Disclaimer of Liability

*Information contained in this document is company private to ADC DSL Systems, Inc., and shall not be modified, used, copied, reproduced or disclosed in whole or in part without the written consent of ADC.*

*Contents herein are current as of the date of publication. ADC reserves the right to change the contents without prior notice. In no event shall ADC be liable for any damages resulting from loss of data, loss of use, or loss of profits, and ADC further disclaims any and all liability for indirect, incidental, special, consequential or other similar damages. This disclaimer of liability applies to all products, publications and services during and after the warranty period.*

## USING THIS MANUAL

Two types of messages, identified by icons, appear in the text.



**Notes contain information about special circumstances.**



**Cautions indicate the possibility of equipment damage or the possibility of personal injury.**

## UNPACK AND INSPECT YOUR SHIPMENT

Upon receipt of the equipment:

- Unpack each container and inspect the contents for signs of damage. If the equipment has been damaged in transit, immediately report the extent of damage to the transportation company and to ADC DSL Systems, Inc. Order replacement equipment, if necessary.
- Check the packing list to ensure complete and accurate shipment of each listed item. If the shipment is short or irregular, contact ADC DSL Systems, Inc. as described in “[Appendix C - Glossary](#)” on page 18. If you must store the equipment for a prolonged period, store the equipment in its original container.

# TABLE OF CONTENTS

<b>Overview</b>	<b>1</b>
Features .....	1
Applications.....	2
<b>Product Description</b>	<b>3</b>
External Mechanics .....	4
Status LED .....	4
HRE-500 Stub .....	5
Ground Wire .....	6
End Cap.....	6
Internal Mechanics .....	7
Card-edge Connector .....	8
Gas-tube Protectors .....	8
Thermal Deployment Limits.....	8
Bar Code and Configuration Number Information .....	9
<b>Installation</b>	<b>10</b>
Installation Kit.....	10
Tools .....	10
Installing Doublers .....	11
Mounting the Enclosure .....	13
Grounding.....	14
<b>Appendix A - Specifications</b>	<b>15</b>
<b>Appendix B - Product Support</b>	<b>16</b>
<b>Appendix C - Glossary</b>	<b>18</b>
<b>Certification and Warranty</b>	<b>19</b>

# OVERVIEW

The ADC® HiGain® Remote Enclosure Model HRE-500 List 1 is a weatherproof, outdoor, single-slot enclosure that houses one of the following units:

- HiGain Mini Doublers
  - HDU-217
  - HDU-219
  - HDU-437
  - HDU-439
- HiGain Micro Doublers
  - HDU-409
  - HDU-407
- 239 T1 Repeater
- ETSI Mini Doublers
  - EDU-840
  - EDU-841

# FEATURES

- compact dimensions
- eliminates need for expensive controlled environmental vaults
- unaffected by dust, wind, rain, sleet, ice, and snow
- easily mounted with two screws on a wall or pole
- weather-sealing cable fittings that protect connections and provide strain relief
- easy-open bottom cap, secured by one retaining screw and five compression bolts
- compatible with above and below ground installations
- replaceable gas tube surge voltage protection on all four ports

## APPLICATIONS

The HRE-500 List 1 houses doublers and allows quick and easy deployment of an ADC single or multi-doubler circuit, as shown in [Figure 1](#).

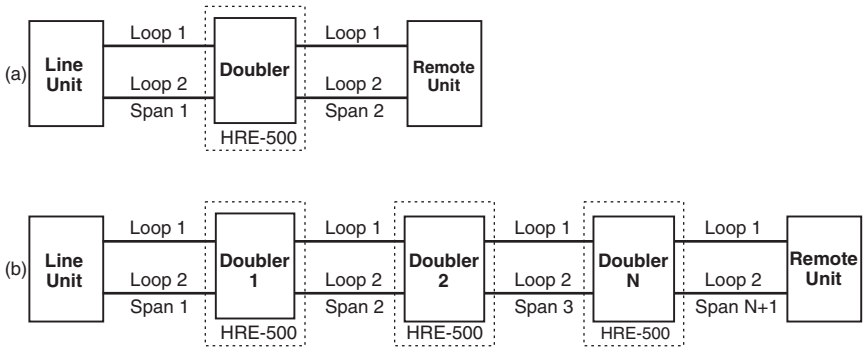

**Figure 1.** *HRE-500 List 1 Applications*

# PRODUCT DESCRIPTION

The HRE-500 List 1 includes:

- External mechanics featuring:
  - Status LED viewing hole
  - 20-foot gel-filled stub
  - Ground wire
  - End cap
- Internal mechanics featuring:
  - Card-edge connector
  - Gas-tube protectors

## EXTERNAL MECHANICS

Figure 2 shows the external mechanics of the HRE-500 List 1 including the status LED viewing lens, cable stub wiring assignments and enclosure dimensions.

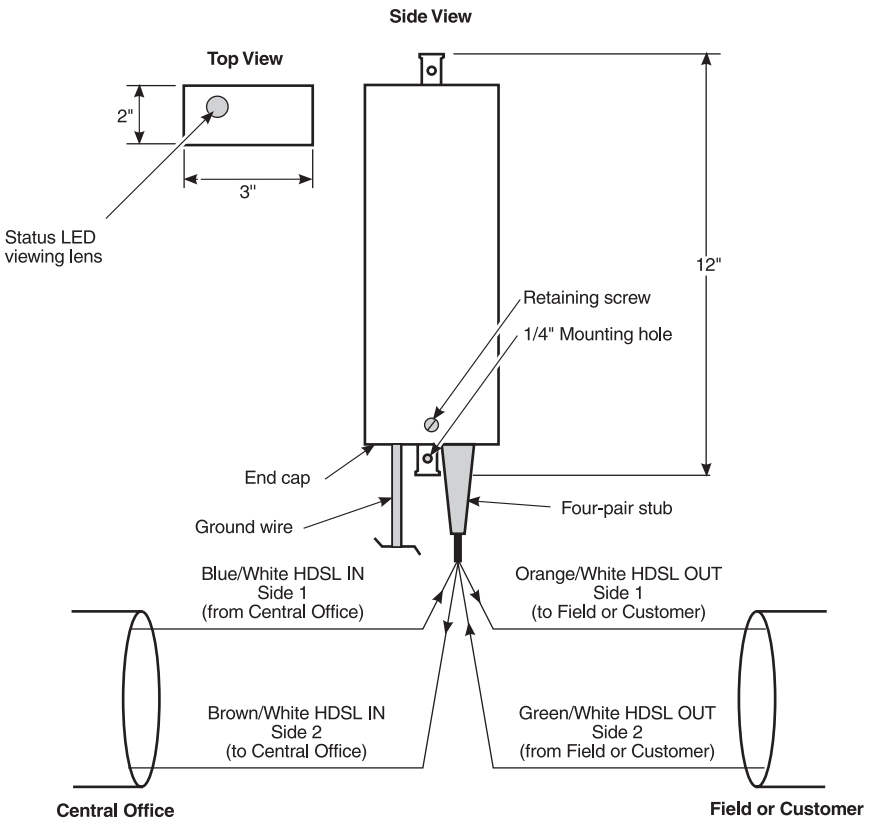

Figure 2. HRE-500 List 1 External Mechanics

### Status LED

The doubler single state LED can be viewed through the housing shown in Figure 2. Consult the appropriate doubler practice for information regarding the status LED.



## HRE-500 Stub

The HRE has a 14 AWG, stranded ground wire and a four-pair, 20-foot gel-filled stub for access to the doubler's four ports. This 24 AWG stub has foam skin insulation and a filled jacket. Each conductor has a dual insulation consisting of an inner coating of natural, insulating-grade, high-density cellular polyethylene covered by an outer skin of color-coded, high-density solid polyethylene. Standard color codes allow for pair identification with color compounds chosen for electrical balance and permanency. The assembly is flooded with an Electro Thermo Plastic Rubber (ETPR) compound, filling the air space between conductors.

A non-hygroscopic core wrap protects the core and provides improved mechanical and electrical characteristics. The inner surface of the core wrap is coated with the ETPR filling compound. The outer surface is coated with an amorphous polypropylene compound. The cable core shield is a corrugated copolymer-coated 8 mil aluminum tape. The outer jacket consists of a black, low-density polyethylene material providing a flexible protective covering that withstands exposure to sunlight, atmospheric temperatures, ground chemicals and stresses expected in standard installations. The cable complies with the requirements of ANSI/ICEA S-84-608-1994 and has an outside diameter of 0.38 inches (10 mm).

The stub's four pairs terminate on an internal assembly that contains the card-edge connector and gas tube protector board. The stub pairs are routed through a ferrite coil, which prevents EMI energy from exiting the stub pairs.

Figure 3 shows the identity of the four ports for each cable stub to provide access. The CO ports connect to the upstream cable pair connections of either another doubler or the line unit. The field ports connect to the downstream cable pair connections of either another doubler or remote unit.

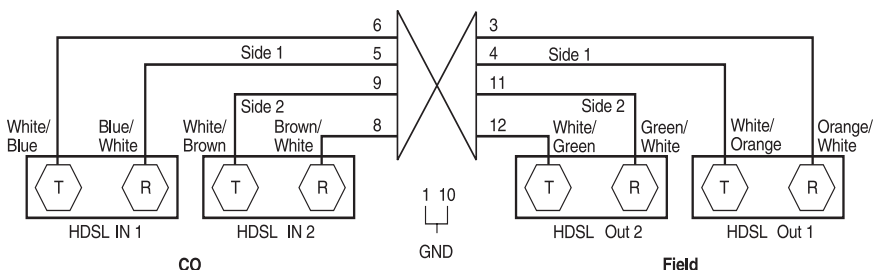

**Figure 3.** HRE-500 Wiring Diagram

## **Ground Wire**

The ground wire is required for both EMI and voltage surge protection for the installed doubler.

## **End Cap**

There are five compression bolts on the end cap which work to create a waterproof barrier. When properly torqued, these bolts compress the neoprene washer (shown in [Figure 4](#)) that sits between the enclosure's two end plates. The washer expands against the sides of the enclosure to form a waterproof barrier. This allows the enclosure to be installed anywhere in the network, including underground locations where it may be submerged in water.

# INTERNAL MECHANICS

Figure 4 shows a front view of the HRE-500.

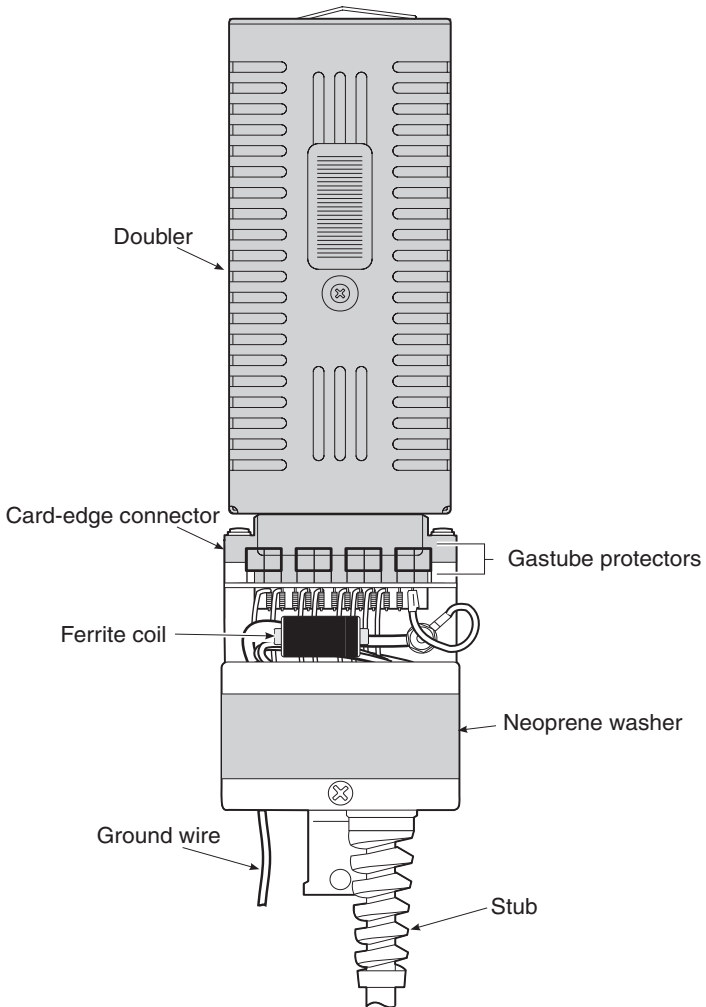

**Figure 4.** HRE-500 List 1 Internal Mechanics

## Card-edge Connector

See [Figure 3 on page 5](#) for the wiring diagram specifications.

## Gas-tube Protectors

The four replaceable gas-tube protectors are equivalent to a TII 47BT and have a breakdown voltage ranging from 300 V to 500 V. The breakdown voltage is a function of voltage rise-time. The tubes can withstand at least 400, 10/1000, 500 Amp discharges.



**A replacement kit containing 20, TII 47BT, gas-tube protectors is available from ADC (part #132-1028-01). See [“Appendix B - Product Support” on page 16](#) for ordering information.**

## Thermal Deployment Limits

HRE-500 and its doubler can be deployed in an ambient temperature up to 135 °F (57 °C) with full solar load and 145 °F (63 °C) without solar load.

## BAR CODE AND CONFIGURATION NUMBER INFORMATION

Figure 5 shows the locations of the bar code and configuration number labels. Table 1 gives a brief description of what the label represents.

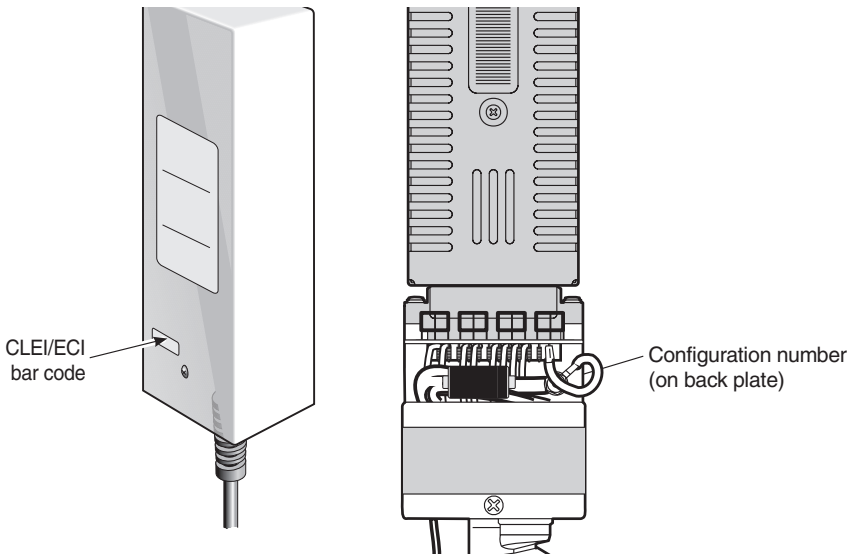

*Figure 5. Bar Code and Configuration Number Locations*

*Table 1. Bar Code and Configuration Number Label Descriptions*

Number	Components
CLEI/ECI Bar Code Label	Contains human-readable Common Language Equipment Identifier (CLEI) number and Equipment Catalog Item (ECI) bar code number.
Configuration Number	This label contains the configuration or revision number, the part number, the Julian date, and a barcoded serial number.

# INSTALLATION

This section provides information on installing a doubler or repeater in the HRE-500 List 1 and on mounting the enclosure. Part number and wiring information are also included.

## INSTALLATION KIT

The HRE-500 installation kit components are listed in [Table 2](#). If any items are missing, or if the shipment is damaged, please contact your ADC sales representative.

*Table 2. Installation Kit*

Part Number	Quantity	Description
150-500-100	1	HiGain Remote Enclosure (HRE) 500 Technical Practice
670-1018-24	2	Screws, 12 x 1 in.
673-1095-01	1	3/16 in. Hex (Allen) Wrench
672-1001-04	2	Flat Washers 1/4 in. inside diameter (ID) 1/2 in. outside diameter (OD)
671-1002-04	2	Anchor nuts

## TOOLS

To install the HRE-500, you need the following tools:

- flathead screwdriver
- drill
- wood, metal or concrete drill bit, depending on the installation surface
- torque wrench

## INSTALLING DOUBLERS

To install a doubler in the HRE-500:

- 1 Remove the small retaining screw from the lower front side of the case (see [Figure 2 on page 4](#)).
- 2 Loosen, but do not remove, the five compression bolts from the end cap (see [Figure 2](#)), then remove the end cap.
- 3 Insert the doubler or repeater into the end cap's connector.
- 4 Replace the case, then insert the retaining screw.
- 5 Torque the five compression bolts in the proper sequence shown in [Figure 6](#) and [Table 3 on page 12](#)).



The five compression bolts must be torqued according to their specified torque levels and in the numerical sequence shown in [Table 3 on page 12](#).

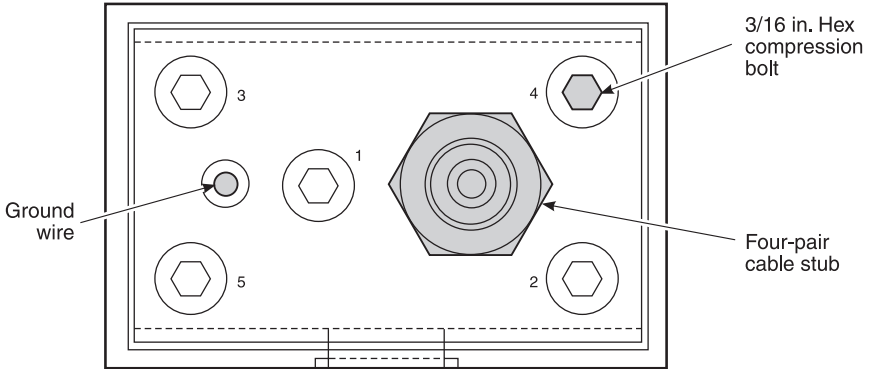

**Figure 6.** End Cap Compression Bolts



**Always follow the torquing sequence in [Table 3](#). Exact torquing pressure is only required for installation in which the HRE-500 may be submerged in water. Approximate torquing is sufficient in all other installations.**

*Table 3. Torque Sequence Chart*

<b>Number Sequence</b>	<b>Torque</b>
1	60 inch/pounds
2	65 inch/pounds
3	65 inch/pounds
4	65 inch/pounds
5	65 inch/pounds
1	85 inch/pounds
2	85 inch/pounds
3	85 inch/pounds
4	85 inch/pounds
5	85 inch/pounds
1	90 inch/pounds



## MOUNTING THE ENCLOSURE

To mount the enclosure:

- 1 Select a location for mounting the HRE-500 that allows access to wiring and grounding connections through the cable fittings on the bottom of the HRE-500.
- 2 Place the HRE-500 in the chosen mounting location, then mark the mounting hole locations. [Figure 7](#) shows the mounting hole locations on the enclosure.

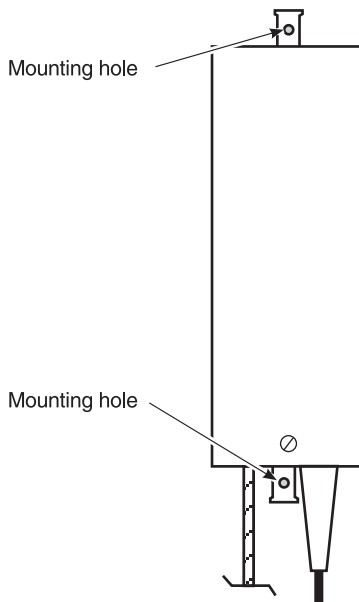

**Figure 7.** *Mounting Hole Locations (Front View)*

- 3 Do one of the following:
  - If the installation location is wood, use a drill with a wood or metal drill bit to drill mounting screw holes into the surface.
  - If the installation location is concrete, use a drill with a concrete drill bit that is slightly smaller than the diameter of the anchor nuts to drill the mounting screw holes into the concrete surface.
- 4 Insert the anchor nuts into the pilot holes and tap the anchor nuts into place with a hammer.
- 5 Use a  $\frac{1}{4}$  inch slotted screwdriver to fasten the enclosure onto the mounting location using the two screws and two washers provided in the installation kit.

## GROUNDING

The stub shield is not connected to the enclosure ground. When the stub is spliced with the main cable the stub shield should be connected to the field cable shield. Failure to do so will expose the signal pairs to stray EMI which could introduce service affecting noise into the information payload. The green ground wire must also be properly grounded to provide both EMI and voltage surge protection to the doubler.

# APPENDIX A - SPECIFICATIONS

The HRE-500 List 1 outer enclosure has the following specifications:

<b>Length</b>	12 in. (30.7 cm.)
<b>Width</b>	3 in. (7.7 cm.)
<b>Depth</b>	2 in. (5.12 cm.)
<b>Weight</b>	2.5 lbs. (1.13 kg.)

# APPENDIX B - PRODUCT SUPPORT

ADC Customer Service Group provides expert pre-sales and post-sales support and training for all its products.

Technical support is available 24 hours a day, 7 days a week by contacting the ADC Technical Assistance Center (TAC).

## **Sales Assistance**

800.366.3891 extension 73000  
(USA and Canada)  
952.917.3000  
Fax: 952.917.3237

- Quotation Proposals
- Ordering and Delivery
- General Product Information

## **Systems Integration**

800.366.3891, extension 73000  
(USA and Canada)  
952.917.3000

- Complete Solutions (from concept to installation)
- Network Design and Integration Testing
- System Turn-Up and Testing
- Network Monitoring (upstream or downstream)
- Power Monitoring and Remote Surveillance
- Service/Maintenance Agreements
- Systems Operation

## **ADC Technical Assistance Center**

800.638.0031  
714.730.3222  
Fax: 714.730.2400  
Email: [wsd\\_support@adc.com](mailto:wsd_support@adc.com)

- Technical Information
- System/Network Configuration
- Product Specification and Application
- Training (product-specific)
- Installation and Operation Assistance
- Troubleshooting and Repair/Field Assistance

## **Online Technical Support**

- [www.adc.com/Knowledge\\_Base/index.jsp](http://www.adc.com/Knowledge_Base/index.jsp)

## **Online Technical Publications**

- [www.adc.com/library1/](http://www.adc.com/library1/)

**Product Return Department**

800.366.3891 ext. 73748 or

952.917.3748

Fax: 952.917.3237

Email: [repair&return@adc.com](mailto:repair&return@adc.com)

- ADC Return Material Authorization (RMA) number and instructions must be obtained before returning products.

*All telephone numbers with an 800 prefix are toll-free in the USA and Canada.*

# APPENDIX C - GLOSSARY

Abbreviations used throughout this manual are defined below:

<b>ANSI</b>	American National Standards Institute
<b>AWG</b>	American Wire Gauge
<b>CLEI</b>	Common Language Equipment Identifier
<b>CO</b>	Central Office
<b>ECI</b>	Equipment Catalog Item
<b>EDU</b>	HiGain Doubler Unit
<b>EMI</b>	ElectroMagnetic Interference
<b>ETPR</b>	Electro Thermo Plastic Rubber
<b>ETSI</b>	European Telecommunications Standards Institute
<b>HDU</b>	HiGain Doubler Unit
<b>HRE</b>	HiGain Remote Enclosure
<b>ICEA</b>	Insulated Cable Engineers Association
<b>LED</b>	Light Emitting Diode
<b>RMA</b>	Return Material Authorization

---

# CERTIFICATION AND WARRANTY

## LIMITED WARRANTY

ADC DSL Systems, Incorporated (“ADC”) warrants that, for a period of sixty (60) months from the date of shipment, the hardware portion of its products will be free of material defects and faulty workmanship under normal use. ADC's obligation, under this warranty, is limited to replacing or repairing, at ADC's option, any such hardware product which is returned during the 60-month warranty period per ADC's instructions and which product is confirmed by ADC not to comply with the foregoing warranty.

The transportation charges for shipment of returned products to ADC will be prepaid by the Buyer. ADC will pay transportation charges for shipment of replacement products to Buyer, unless no trouble is found (NTF), in which case the Buyer will pay transportation charges.

ADC may use reconditioned parts for such repair or replacement. This warranty *does not* apply to any product which has been repaired, worked upon, or altered by persons not authorized by ADC or in ADC's sole judgment has subjected to misuse, accident, fire or other casualty, or operation beyond its design range.

Repaired products have a 90-day warranty, or until the end of the original warranty period—whichever period is greater.

ADC DISCLAIMS ALL OTHER WARRANTIES, EITHER EXPRESS OR IMPLIED, INCLUDING BUT NOT LIMITED TO IMPLIED WARRANTIES OF MERCHANTABILITY AND FITNESS FOR A PARTICULAR PURPOSE, WITH RESPECT TO ITS PRODUCTS AND ANY ACCOMPANYING WRITTEN MATERIALS. FURTHER, ADC DOES NOT WARRANT THAT SOFTWARE WILL BE FREE FROM BUGS OR THAT ITS USE WILL BE UNINTERRUPTED OR REGARDING THE USE, OR THE RESULTS OF THE USE, OF THE SOFTWARE IN TERMS OF CORRECTNESS, ACCURACY, RELIABILITY OR OTHERWISE.

## MODIFICATIONS

Any changes or modifications made to this device that are not expressly approved by ADC, may void the user's warranty. All wiring external to the products should follow the provisions of the current edition of the National Electrical Code.

## STANDARDS COMPLIANCE

This product has been tested and verified to comply with the applicable sections of the following standards.

- TR TSY-000056,
- IEC/CEI/ETS-682, Extended Series T4.1E

For technical assistance, refer to “Appendix B - Product Support” on page 16.

---

**ADC DSL Systems, Inc.**

14402 Franklin Avenue  
Tustin, CA 92780-7013

Tel: 714.832.9922

Fax: 714.832.9924

**Technical Assistance**

Tel: 800.638.0031

Tel: 714.730.3222

Fax: 714.730.2400



DOCUMENT: 150-500-100-05



1240066