

PG-FLEX™ 24 CHANNEL RT LINE UNIT MODEL FRL-742

List #	PairGain #	CLEI Code
1	150-1342-01	VARHDF0CAA
2	150-1342-02	VARHDF0CAA

CONTENTS	PAGE
A. PRODUCT OVERVIEW	
1. DESCRIPTION AND FEATURES	2
2. APPLICATIONS	2
3. SPECIFICATIONS	3
4. CERTIFICATION	4
5. WARRANTY	4
B. FUNCTIONAL DESCRIPTION	
6. OPERATIONAL CAPABILITIES	4
7. FRONT PANEL	6
8. TERMINAL MANAGEMENT	7
C. INSTALLATION AND TEST	
9. UNPACKING	10
10. TURN-UP AND TESTING	10
11. TROUBLESHOOTING	10

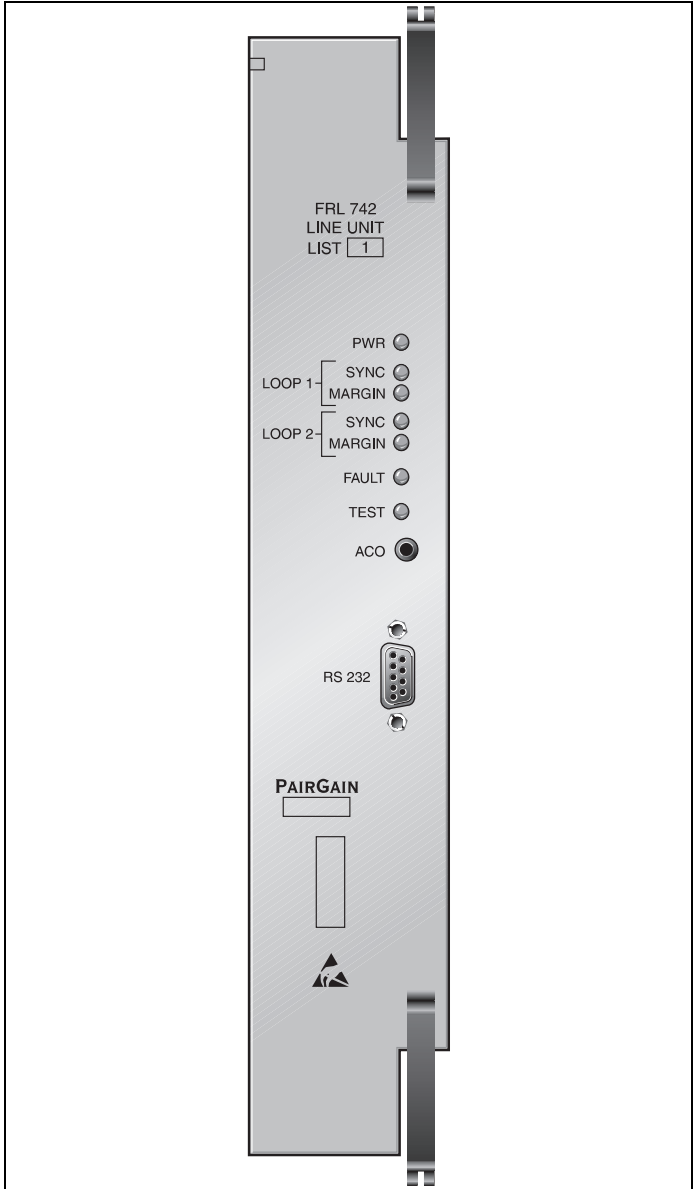

Figure 1. FRL-742 RT Line Unit Front Panel. The PairGain FRL-742 is the remote end of the PG-Flex subscriber carrier system.

CAUTION

This product incorporates static sensitive components. Proper electrostatic discharge procedures must be followed.

A. PRODUCT OVERVIEW

1. DESCRIPTION AND FEATURES

1.01 The PG-Flex FRL-742 Remote Terminal (RT) Line Unit is the remote end of the PG-Flex subscriber carrier system that uses two pairs of unconditioned copper wire as a carrier for up to 24 independent subscriber channels between a Central Office Terminal (COT) and the RT. The FRL-742 RT Line Unit uses PairGain's High-bit-rate Digital Subscriber Line (HDSL) technology to provide the equivalent of 1.544 Mbps digital transmission rates, plus signaling over two copper pairs without the need for repeaters, loop conditioning, or pair selection. The List 1 supports 4Tel compatibility loop test systems. The List 2 provides both 4Tel and MLT/PGTC compatibility.

1.02 The FRL-742 RT Line Unit resides in a PairGain RT Enclosure; one FRL-742 RT Line Unit is required for the system.

1.03 Revision History of this practice.

Revision 02—December 18, 1996

a) Added List 2.

1.04 FRL-742 RT Line Unit features:

- Distributed subscriber carrier system architecture
- Proven PairGain HDSL (2B1Q) technology operates on unconditioned copper pairs
 - Bridge Taps
 - No Pair Selection
 - No Repeater
- 4Tel Loop Test System compatibility (List 1, 2)
- MLT/PGTC Loop Test System compatibility (List 2)

2. APPLICATIONS

2.01 PG-Flex is a small capacity universal subscriber carrier system supporting up to 24 subscriber channels, including POTS and ISDN services. The system is based on HDSL transmission technology and the remote power is powered from the central office. Using two 24 gauge unconditioned copper pairs, the remote terminal may be located up to 12.3 kft from the central office terminal. Standard 19- or 23-inch shelves contain multiple systems; circuit cards may be hot-swapped without affecting other systems installed in the shelf. POTS channel units use 64-kbps μ -Law PCM encoding to allow Group 3 facsimile or high-speed modem operation on all channels.

2.02 System Flex Configuration. A PG-Flex system, shown in Figure 2 consists of:

- Central Office Terminal (COT). Two complete systems may be installed in a 19-inch COT Shelf and

four complete systems may be installed in a 23-inch COT Shelf. Each system requires one COT Line Unit and up to three (23-inch shelf) or six (19-inch shelf) Channel Units. A common Alarm Unit or Pair Gain Test Controller Interface Unit in each shelf provides an interface for maintenance alarm relays and metallic access to the remote subscriber lines.

- Remote Terminal (RT). The RT Enclosure provides a weatherproof housing for the PG-Flex remote electronics and subscriber terminations. The enclosure accepts one common RT Line Unit and up to four Channel Units. The Remote Terminal communicates with, and is line-powered from, the COT over two pairs of 19- to 26-gauge twisted-pair telephone wire. Each pair carries both power and HDSL signaling.

2.03 HDSL Transmission. PG-Flex utilizes HDSL transmission technology between the COT and RT and provides up to 24 DS0s, plus signaling, over two copper pairs without the need for repeaters, loop conditioning, or pair selection. Adaptive equalization, scrambling, and a four-level 2B1Q line coding scheme increase range and minimizes crosstalk.

2.04 The line interface is a two-pair, 784-kbps full-duplex 2B1Q transmission format. The dual HDSL lines provide 24 64-kbps channels with signaling, and an embedded operations channel for management control. The signal characteristics on the carrier pairs comply with TR-NWT-001210, Generic Requirements for High-bit-rate Digital Subscriber Line (HDSL) Systems.

2.05 For the system configuration shown in Figure 2, the maximum distance between the COT and the RT is 12.3 kft (3.8 km), assuming the HDSL lines are 24 gauge. Table 1 shows the maximum distance between the COT and RT for various gauge wire. Due to the nature of HDSL transmission technology, the HDSL lines do not require any special conditioning and may include unterminated bridge taps, but cannot include load coils.

2.06 Subscriber Drop Testing. For subscriber drop testing from the central office, PG-Flex is able to select and connect any subscriber drop to a metallic test pair at the RT. PG-Flex extends this connection back to the COT where it can be switched onto the test access bus, or to the corresponding subscriber line on the COT channel card.

2.07 Test access may be achieved by placing +116 V on the subscriber's COT tip lead for 1.5 seconds, then removing the +116 V. Depending on the configuration of the PG-Flex system, the selected subscriber drop (assuming a working metallic bypass pair) will be connected to either the corresponding COT subscriber line or to the test access bus.

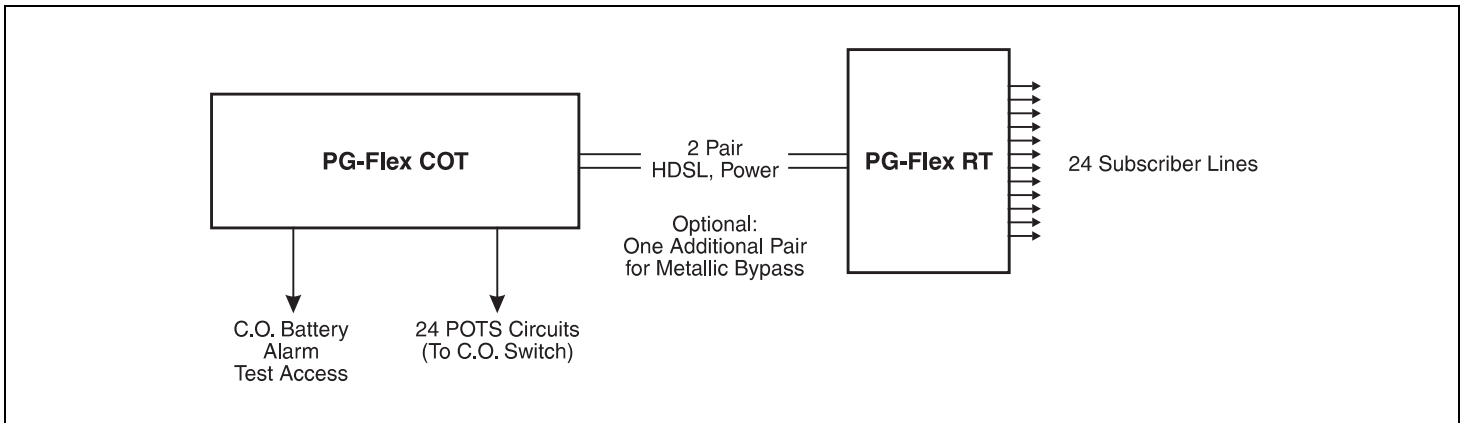

Figure 2. Typical PG-Flex Configuration.

TABLE 1. PG-FLEX DISTANCES

Wire Gauge	Loop Length	
	12/24 Channel System	Resistance
26 AWG (0.4 mm)	9.0 kft (2.8 km)	750 Ω
24 AWG (0.5 mm)	12.3 kft (3.8 km)	638 Ω
22 AWG (0.6 mm)	16.1 kft (5.0 km)	521 Ω
19 AWG (0.9 mm)	22.8 kft (7.0 km)	367 Ω

2.08 The test connection will be dropped when -116V is applied to the subscriber's COT tip for 1.5 seconds, then removing the -116 V.

2.09 Test access may also be activated through the RS-232 Maintenance Port located on the front of the COT and RT Line Units, using an ASCII terminal.

3. SPECIFICATIONS

RT Power Supply Input Voltage

+130 Vdc to +65 Vdc (Line 1)
-130 Vdc to 0 Vdc (Line 2)

Input Power (typical)

Less than 30 Watts

Operating Temperature & Humidity

-40° F to + 150° F (-40° C to +65° C)
5% to 95% (non-condensing)

Operating Elevation

-200 ft to 13,000 ft (-60 m to 4,000 m)

Dimensions

Height: 12.00" (30.5 cm)
Width: 2.25" (5.7 cm)
Depth: 4.50" (11.4 cm)

Weight

1.4 lb. (0.6 kg)

4. CERTIFICATION

4.01 FCC Compliance. The FRL-742 RT Line Unit complies with the limits for Class A digital devices pursuant to Part 15 of the FCC rules. These limits are designed to provide reasonable protection against harmful interference when the equipment is operated in a commercial environment. This equipment generates, uses and can radiate radio frequency energy and, if not installed and used in accordance with the instruction manual, may cause harmful interference to radio communications. Operation of this equipment in a residential area is likely to cause harmful interference in which case the user will be required to correct the interference at his own expense.

4.02 Refer to the installation section of the appropriate instruction manual for the unit you are installing to get information on:

- Cabling
- Proper connections
- Grounding
- Line vs. local power

4.03 All wiring external to the product(s) should follow the provisions of the current edition of the National Electrical Code.

5. WARRANTY

5.01 PairGain Technologies warrants this product to be free of defects and to be fully functional for a period of 5 years from the date of original shipment, given proper customer installation and regular maintenance. PairGain will repair or replace any unit without cost during this period if the unit is found to be defective for any reason other than abuse or improper use or installation.

5.02 This module should not be field repaired. If it fails, replace it with another unit and return the faulty unit to PairGain for repair. Any modifications of the unit by anyone other than an authorized PairGain representative will void the warranty.

5.03 If a unit needs repair, call PairGain for a Return Material Authorization (RMA) number and return the defective unit, freight prepaid, along with a brief description of the problem, to:

PairGain Technologies, Inc.
2120 Ritchey St.
Santa Ana, CA 92705-5101
ATTN: Repair and Return Dept.
(714) 832-9922
(800) 638-0031

5.04 PairGain will continue to repair faulty modules beyond the warranty program at a nominal charge. Contact your PairGain sales representative for details and pricing.

B. FUNCTIONAL DESCRIPTION

6. OPERATIONAL CAPABILITIES

6.01 The FRL-742 RT Line Unit includes a remote (line-powered) power supply, HDSL line transceivers, performance status indicators, and RS-232 Maintenance Port (see Figure 3). Through the Maintenance Port, the system configuration and status may be checked and HDSL performance monitored. Changes to the system configuration and or test access cannot be made through the RT line unit.

6.02 The RT Line Unit provides the following functions:

- Power Supply
- HDSL Line Transceivers
- Front-Panel Status Indicators
- Alarm Cut-Off Switch
- RS-232 Maintenance Interface (DCE)
- Line and Drop Test Circuits
- MLT/PGTC Loop Test System (List 2) compatibility
- 4Tel Loop Test System (List 1, 2) compatibility

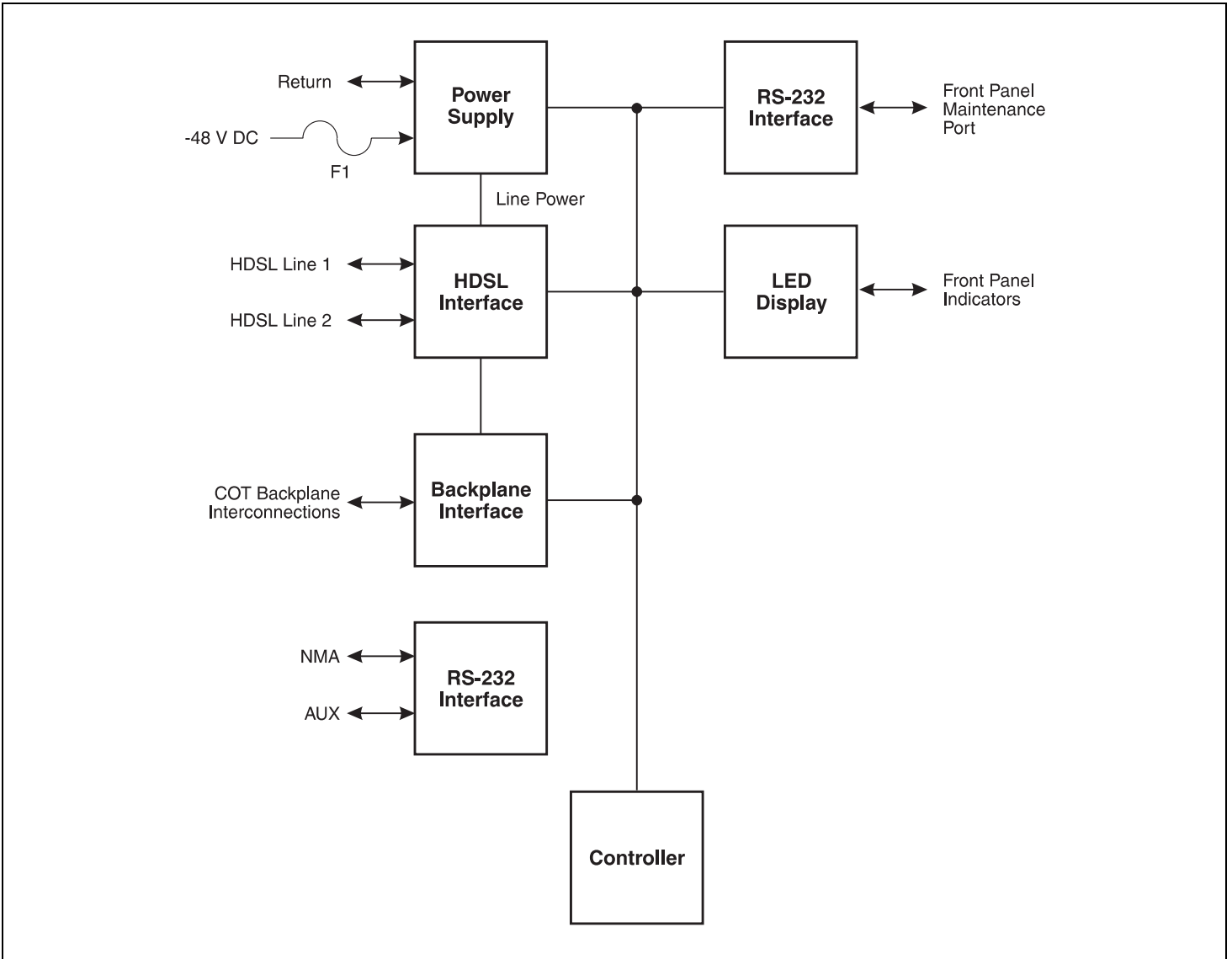

Figure 3. FRL-742 Block Diagram.

7. FRONT PANEL

7.01 The front panel of the FRL-742 contains the following switch, indicators, and connector (see Figure 1):

- **POWER LED Indicator**

Green—power is applied and the line feed is normal.

Off—the system is not receiving power. The COT Line Unit fuse may have blown, or the HDSL line(s) may be open.

- **LOOP 1 SYNC LED Indicator**

Green—HDSL line 1 is in sync between the COT and RT.

Flashing Green—HDSL line 1 is attempting to synchronize with the remote unit.

Off—HDSL line 1 does not detect an active remote unit.

- **LOOP 1 MARGIN LED Indicator**

Yellow—HDSL line 1 margin is below a preset level.

Off—HDSL line 1 margin is above the preset level.

- **LOOP 2 SYNC LED Indicator**

Green—HDSL line 2 is in sync between the COT and RT.

Flashing Green—HDSL line 2 is attempting to synchronize with the remote unit.

Off—HDSL line 2 does not detect an active remote unit.

- **LOOP 2 MARGIN LED Indicator**

Yellow—HDSL line 2 margin is below a preset level.

Off—HDSL line 2 margin is above the preset level.

- **TEST LED Indicator**

Yellow—a subscriber drop or diagnostic test has been activated at any unit in the system.

Off—there are no tests activated in the system.

- **FAULT LED Indicator**

Red—there is a fault in the system.

Off—no faults are detected in the system.

- **ACO Pushbutton**

Pressing this pushbutton will silence any audible indicators in the central office resulting from a PG-Flex major or minor alarm. This pushbutton also functions as an LED test by turning on all LEDs when pressed and held for at least 2 seconds. When the pushbutton is released, LEDs resume their normal status indications. The LEDs remain active for 2 minutes, at which time the channel unit LEDs turn off to conserve power at the remote terminal.

- **RS-232 DB-9F Connector**

This connector is used by technicians to check the configuration and status of the PG-Flex. This is a DCE interface and requires DTE active from the terminal to prevent automatic log off.

8. TERMINAL MANAGEMENT

8.01 The terminal management function at the remote terminal enables a technician to monitor the entire PG-Flex system through an ASCII terminal (or equivalent) connected to the maintenance port. The pin-outs for the standard RS-232 (DB-9) maintenance port connector are shown in Figure 4. With the management function, the technician can view status, configuration, performance, and inventory information, but cannot make any changes or initiate a subscriber test access.

8.02 Craft Maintenance Port. The craft maintenance port to which the management terminal connects is available at both the CO Line Unit and all RT Line Units. The craft port is set up as DCE with 8 data bits, 1 stop bit, and no parity. Press the space bar several times invokes the autobaud feature, which covers a 1,200 to 9,600 bps range.

8.03 Menus and Displays. Figure 5 shows the menu structure of the terminal management system. Table 4 defines the terms appearing on the Status displays. Following are brief descriptions of each menu and display screen:

- **Log On Screen.** The Line Unit displays this screen when it detects the user's input from the maintenance port while in an idle state. Password input is echoed with "*" characters. If the technician does not enter the correct password after 5 tries, the Line Unit locks out the log on procedure for 10 minutes.
- **Main Menu.** After receiving a correct password, the terminal displays the Main Menu from which the technician can choose any of the following options:
 - Status
 - Setup
 - Inventory
- **Status.** By selecting the Status option (A) from the Main Menu, the technician can:
 - Display System Status to show the equipment installed in the system and the current status (in alarm or not) of the equipment. An "*" next to the unit name indicates that the unit is currently in the alarm state.

- Display Channel Status to show the current status of all channels in the system. Each channel has one of the following status conditions:
 - IDLE: The channel is not off-hook or ringing.
 - RING: The channel is ringing.
 - OH: The channel is off-hook.
 - ALRM: The channel is in alarm.
- Display HDSL Status to show the status of all the HDSL segments and request the user to select the segment of the HDSL to be displayed. Each HDSL segment has one of the following status conditions:
 - ACTIVE: The segment is functioning normally.
 - ALARM: The segment is in alarm.
 - NONE: The segment is not equipped.
- Display Performance History to show the 24-hour performance history or the 7-day performance history of the HDSL segment selected.
- Display Alarm History to show the history of all the alarms that have occurred since the last time the history is reset. Alarms are reported with their first occurrence, last occurrence, number of occurrences, and current status.
- **Setup.** By selecting the Setup option (B) from the Main Menu, the technician can view the following information:
 - System Time, Date, and ID
 - Auto Log-Off Time
 - Metered Tone Frequency
 - Ring Frequency
 - HDSL 24-Hour ES Threshold
 - HDSL Margin Alarm Threshold
 - Alarm On Threshold
 - Alarm-On Configuration
- **Inventory.** By selecting the Inventory option (D) from the Main Menu, the technician can view manufacturing information of all the units in the system. At the CO, the command displays all units in the system; at the RT, only those units in the local cage are displayed.

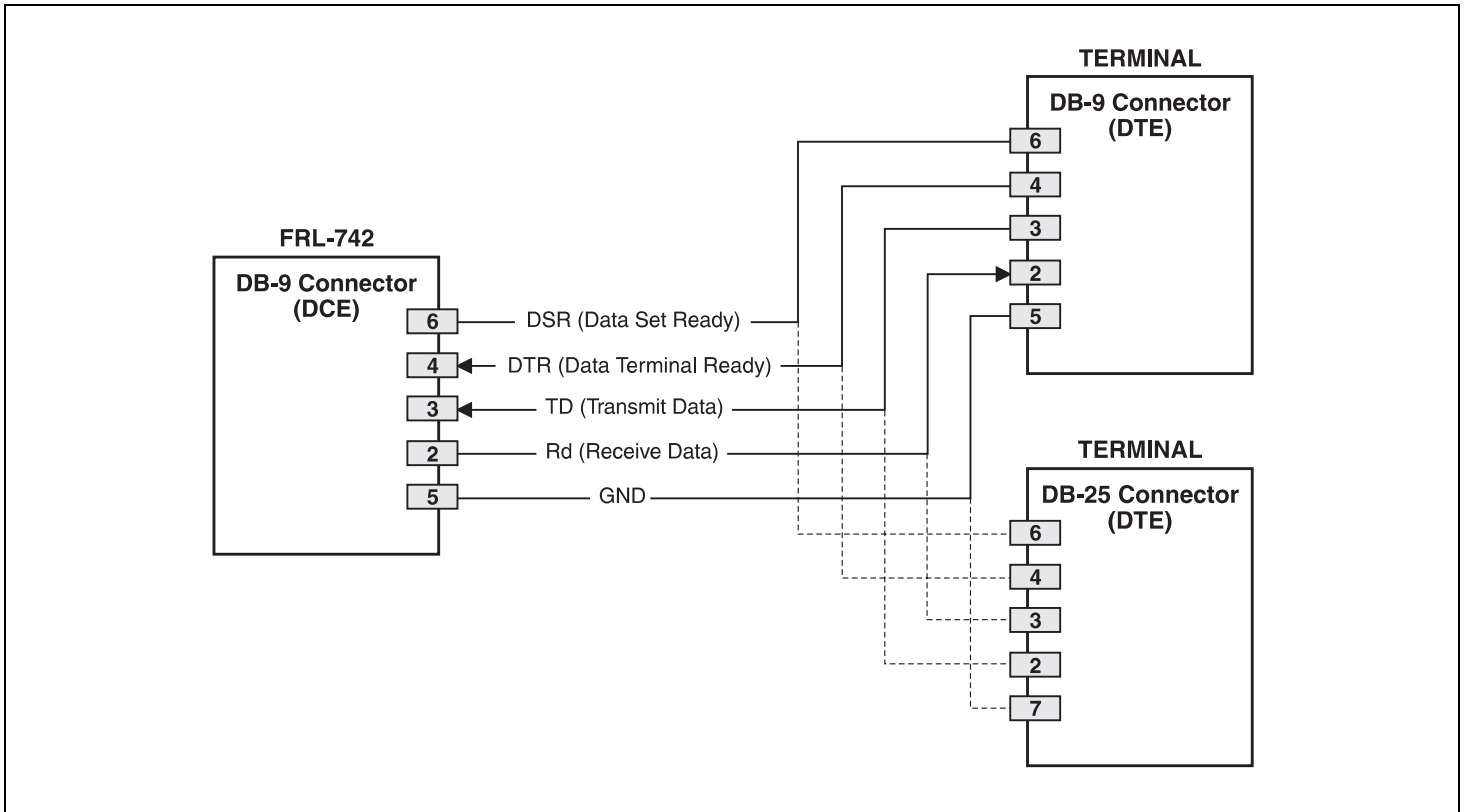

Figure 4. FRL-742 DB-9 Pin Outs. A standard RS-232 (DB-9) connector on the front panel provides access to the menu interface feature via an ASCII terminal.

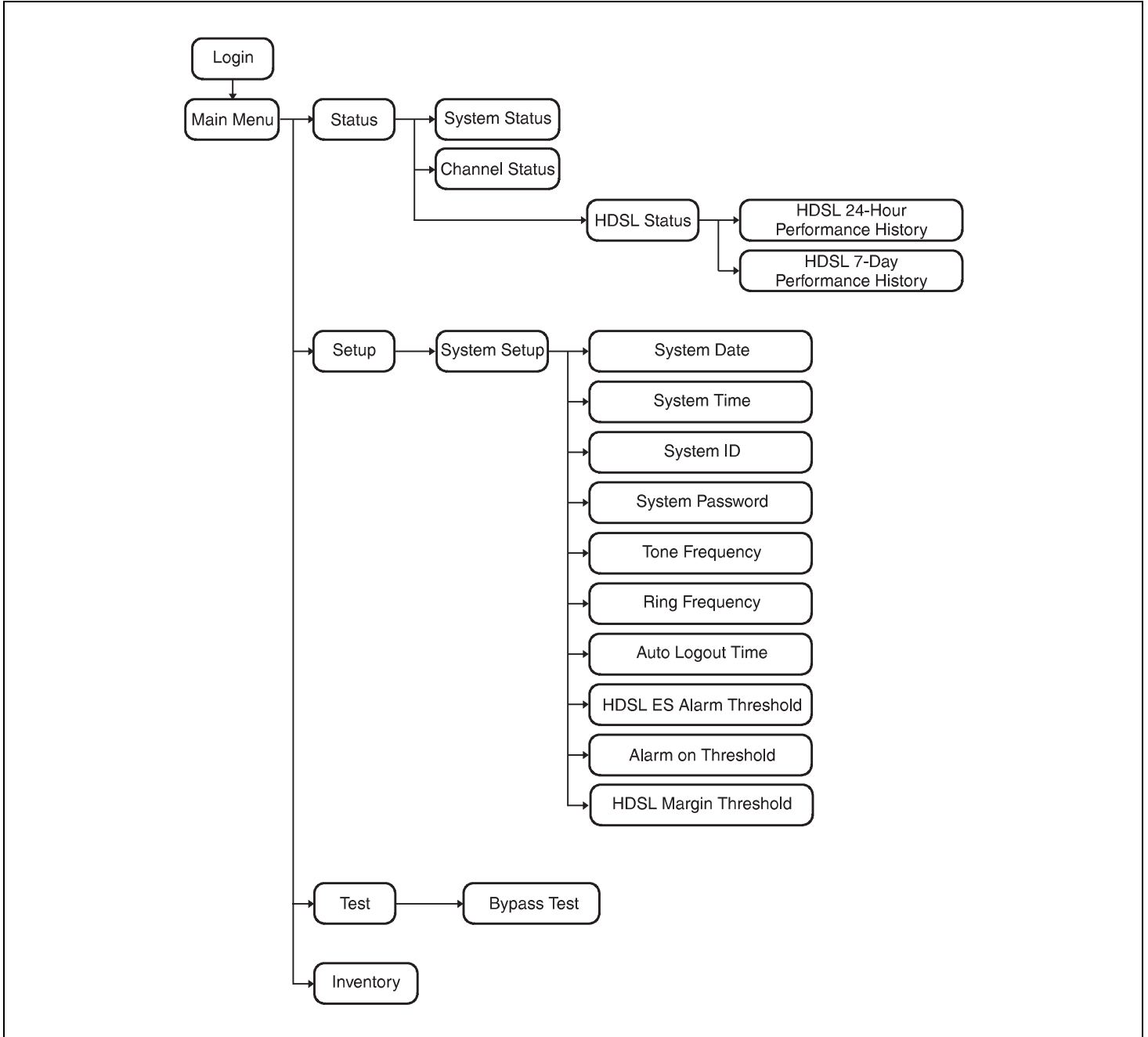

Figure 5. Terminal Menu and Display Structure.

C. INSTALLATION AND TEST

9. UNPACKING

- 9.01** Upon receipt of the equipment, proceed as follows:
1. Unpack each container and visually inspect it for signs of damage. If the equipment has been damaged in transit, immediately report the extent of damage to the transportation company and to PairGain. Order replacement equipment if necessary.
 2. Check the contents versus the packing list to ensure complete and accurate shipment. If the shipment is short or irregular, contact PairGain as described in Section 5. If you must store the equipment for a prolonged period, store the equipment in its original container.

10. TURN-UP AND TESTING

10.01 Table 2 provides step-by-step turn-up and test procedures for the FRL-742 RT Line Unit.

11. TROUBLESHOOTING

11.01 Table 3 provides troubleshooting procedures based on indications displayed by the front panel indicators of FRL-742 RT Line Units. Table 4 contains a glossary of PG-Flex terms.

TABLE 2. FRL-742 RT LINE UNIT TURN-UP AND TESTING

CAUTION																	
Observe normal electrostatic discharge precautions when handling electronic equipment. Do not hold electronic plugs by their connector edges. Do not touch components or circuitry.																	
<i>Step</i>	<i>Operation</i>	<i>Action</i>	<i>Observe</i>														
1	Install RT Line Unit	a. Insert the FRL-742 RT Line Unit into the RT Enclosure.	<ul style="list-style-type: none"> • All LEDs on the RT Line Card turn <i>on</i> for approximately 7 seconds, then scan from top to bottom. • The PWR LED remains <i>on</i>. 														
		b. At both the COT and RT Line Unit, observe the front panel indicators.	<ul style="list-style-type: none"> • After approximately 30 seconds, the SYNC LEDs for Line 1 and Line 2 begin to <i>flash</i>. • Within 35 seconds, the SYNC LEDs for Line 1 and Line 2 turn <i>on</i>. 														
		c. After the system has powered up, established HDSL synchronized communications, and no calls are in progress, observe the RT Line Unit front panel indicators.	<table style="width: 100%; border: none;"> <tr><td>POWER</td><td style="text-align: right;"><i>on</i></td></tr> <tr><td>LOOP 1 SYNC</td><td style="text-align: right;"><i>on</i></td></tr> <tr><td>LOOP 1 MARGIN</td><td style="text-align: right;"><i>off</i></td></tr> <tr><td>LOOP 2 SYNC</td><td style="text-align: right;"><i>on</i></td></tr> <tr><td>LOOP 2 MARGIN</td><td style="text-align: right;"><i>off</i></td></tr> <tr><td>FAULT</td><td style="text-align: right;"><i>off</i></td></tr> <tr><td>TEST</td><td style="text-align: right;"><i>off</i></td></tr> <tr><td>ACO</td><td style="text-align: right;"><i>off</i></td></tr> </table>	POWER	<i>on</i>	LOOP 1 SYNC	<i>on</i>	LOOP 1 MARGIN	<i>off</i>	LOOP 2 SYNC	<i>on</i>	LOOP 2 MARGIN	<i>off</i>	FAULT	<i>off</i>	TEST	<i>off</i>
POWER	<i>on</i>																
LOOP 1 SYNC	<i>on</i>																
LOOP 1 MARGIN	<i>off</i>																
LOOP 2 SYNC	<i>on</i>																
LOOP 2 MARGIN	<i>off</i>																
FAULT	<i>off</i>																
TEST	<i>off</i>																
ACO	<i>off</i>																
2	Measure Voltages	a. Make the following measurement on the RT Enclosure backplane:	130 Vdc to 250 Vdc between HDSL_T and HDSL_T														
		b. Make the following measurements on the COT Shelf backplane:	<ul style="list-style-type: none"> • -130 Vdc, ±10%, between HDSL_T1 and Chassis Ground • 0 Vdc to +120 Vdc between HDSL_T2 and Chassis Ground 														

TABLE 3. FRL-742 RT LINE UNIT TROUBLESHOOTING

<i>Indication</i>	<i>Problem</i>	<i>Action</i>
POWER LED <i>off</i>	1. One or both HDSL lines are no longer connected between the COT and RT. Verify the connections at the RT and COT.	a. Make the following measurement on the RT Enclosure backplane: <ul style="list-style-type: none"> • 130 Vdc to 250 Vdc between HDSL_T and HDSL_T b. Make the following measurements on the COT Shelf backplane: <ul style="list-style-type: none"> • -130 Vdc, $\pm 10\%$, between HDSL_T1 and Chassis Ground • 0 Vdc to +120 Vdc, between HDSL_T2 and Chassis Ground
	2. The COT Line Unit fuse F1 has blown.	Replace the fuse.
	3. The RT Line Unit power supply has failed.	Replace the RT Line Unit.
	4. The COT HDSL power supply has failed.	Replace the COT Line Unit.
LOOP 1 (2) SYNC LED <i>flashing or off</i>	1. The HDSL line is attempting to synchronize with the central office unit or cannot detect the HDSL signal from the central office unit. This is usually an indication that there is a problem with the HDSL circuit between the COT and RT (assuming the FAULT LED is <i>off</i>). 2. COLU and RTLU incompatible i.e. one is a T1 version and the other is an E1.	a. Verify the HDSL circuits are terminated properly and with the correct orientation. b. Measure the loop resistance of each HDSL circuit (shorting the pair at the far end). The loop resistance must be less than that shown in Table 1.
LOOP 1 (2) MARGIN LED <i>on</i>	The HDSL line margin level is below a preset level.	See the previous discussion on the SYNC LED <i>flashing or off</i> .
FAULT LED <i>on</i>	Faulty FRL-742 RT Line Unit.	Replace the RT Line Unit.

TABLE 4. GLOSSARY OF PG-FLEX TERMS

<i>Term</i>	<i>Definition</i>
MARGINS	Indicates the excess signal to noise ratio, at either the COT or RT, relative to a 10^{-7} Bit Error Rate. <i>mn</i> is the current margin, <i>cr</i> is the minimum margin since last cleared, <i>mx</i> is the maximum value since cleared, and N/A means Not Available. The normal range of a typical margin is from 22 to 6 dB.
PULSE ATTENUATION	Indicates the attenuation of the 2B1Q pulse from the distant end. PG-Flex operates with pulse attenuations in excess of 30 dB. This value is related to the cable pair's 196-kHz loss. The pulse attenuation is a more direct indication of the loop attenuation to the 2B1Q signal than the 196-kHz loss. The normal range of pulse attenuation is from 1 to 32 dB
PPM	Indicates the relative offset of the crystal oscillator in the RT Line Unit from the COT Line Unit's crystal oscillator. Any value between -64 and +64 is adequate. Values outside this range indicate out of tolerance components or excessive temperature drift of critical components.
HDSL 24 Hour ES (Errored Seconds)	The number of 1-second intervals that contained at least one CRC error. This value is a running total of the last 24 hours.
HDSL 24 Hour UAS (Unavailable Seconds)	The number of seconds the HDSL loop was out of synchronization. This value is a running total of the last 24 hours.