

# PG-FLEX TECHNICAL PRACTICE

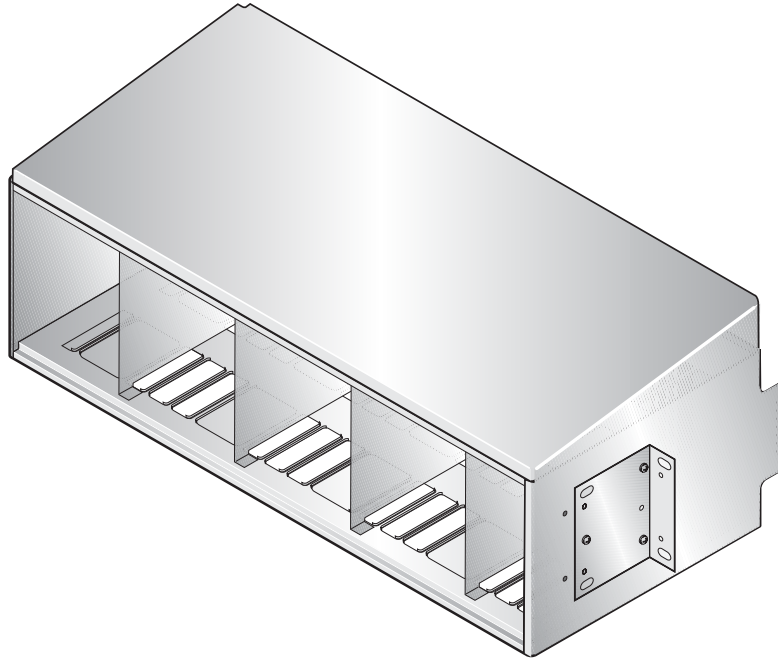

## 23" CENTRAL OFFICE TERMINAL SHELF

Model	List	CLEI Code
FCS-719	4B	VAMCNE0A~~

---

**Revision History of This Practice**

---

<b>Revision</b>	<b>Release Date</b>	<b>Revisions Made</b>
01	October 5, 2001	Initial Release
02	January 27, 2003	Release to rebrand document to comply with ADC standards and update Product Support Information

---

**©Copyright 2003 ADC DSL Systems, Inc. All Rights Reserved.**

*ADC is a registered trademark of ADC Telecommunications, Inc. PG-Flex is a registered trademark of ADC DSL Systems, Inc. No right, license, or interest to such trademarks is granted hereunder, and you agree that you shall assert no such right, license, or interest with respect to such trademarks. Other product names mentioned in this document are used for identification purposes only and may be trademarks or registered trademarks of their respective companies.*

*Information contained in this document is company private to ADC DSL Systems, Inc., and shall not be modified, used, copied, reproduced or disclosed in whole or in part without the written consent of ADC.*

*Contents herein are current as of the date of publication. ADC reserves the right to change specifications at any time without notice. Information furnished by ADC is believed to be accurate and reliable. In no event shall ADC be liable for any damages resulting from the loss of data, loss of use, or loss of profits and ADC further disclaims any and all liability for indirect, incidental, special, consequential or other similar damages. This disclaimer of liability applies to all products, publications and services during and after the warranty period.*

## USING THIS TECHNICAL PRACTICE

Two types of messages, identified by icons, appear in the text:



**Notes contain information about special circumstances.**



**Cautions indicate the possibility of equipment damage or the possibility of personal injury.**



## TABLE OF CONTENTS

<b>Product Overview</b>	<b>1</b>
Description and Features	1
Specifications	2
Electrical Characteristics	2
Environmental	2
Compliance	2
Physical	2
<b>Functional Description</b>	<b>3</b>
Operational Capabilities	3
Backplane Connections	5
<b>Installation and Test</b>	<b>11</b>
Unpacking	11
Selecting HDSL Lines	11
Mounting	12
Wiring	12
Before You Begin	12
Connect the Frame Ground	13
Connect the CO Battery	14
Single Battery Feed	14
Split Battery Feed	15
HDSL Pairs	16
Bypass Pairs	18
Directly Connected Bypass Pairs	18
Shared Bypass Pairs	18
Auxiliary Power Pairs	20
Composite Clock	21
Alarms	22
Alarm Terminations for FPI-729 or FAU-728 List 2	22
Alarm Terminations for FPI-829	23
Subscriber Lines	23
PGTC Connection	25
Fuse	27
Single Battery Feed Fuse	27
Split Battery Feed Fuse	27
Cabling Verification	27
Turn-Up and Testing	27

---

Troubleshooting.....	27
<b>Product Support</b> .....	<b>28</b>
Technical Support.....	28
Limited Warranty .....	28
Returns.....	28
FCC Class A Compliance.....	30
Modifications.....	30
<b>Acronyms</b> .....	<b>31</b>

## LIST OF FIGURES

1. FCS-719 COT Shelf (Card-side, Front View).....	1
2. FCS-719 COT Shelf Backplane .....	9
3. Mounting the FCS-719 COT Shelf.....	12
4. Connecting the Frame Ground (Protection Ground).....	13
5. Connecting a Single Battery Feed.....	14
6. Connecting a Split Battery Feed.....	15
7. Connecting the HDSL Lines .....	16
8. Connecting the Metallic Bypass Pair .....	19
9. Connecting the Composite Clock and Alarms .....	20
10. Connecting the Composite Clock and Alarms .....	21
11. Connecting the PGTC Test Interface Cable .....	25





**LIST OF TABLES**

1. COT Shelf Circuit Utilization .....4

2. Channel Unit Circuit Utilization .....4

3. FCS-719 Card Connectors.....5

4. Alarm Unit or PGTC Interface Unit Connector .....6

5. Line Unit Connectors .....7

6. Channel Unit Connector Pinouts for Systems 1, 2, 3, and 4 .....8

7. FCS-719 COT Shelf Backplane Connectors .....9

8. Battery, CO Battery Return, and Frame Ground .....10

9. LAN Connector .....10

10. DTE Connector (J21) Pinouts .....10

11. 12/24 Channel HDSL Transmission Distances .....11

12. HDSL, Test, And Miscellaneous Connectors.....17

13. Alarm Terminations for FPI-729 or FAU-728 List 2.....22

14. Alarm Terminations for FPI-829.....23

15. Subscriber Amphenol Connectors for Systems 1 through 4\* .....24

16. PGTC Connector Pinouts .....26



# PRODUCT OVERVIEW

This section describes the ADC® PG-Flex® FCS-719 List 4B, 23-inch Central Office Terminal (COT) shelf product features and specifications.

## DESCRIPTION AND FEATURES

The FCS-719 23-inch COT shelf (see [Figure 1](#)) supports:

- one alarm unit or Pair Gain Test Controller (PGTC) Interface unit common to all systems
- up to four PG-Flex subscriber carrier systems where each system comprises one line unit and one to three channel units (for a shelf maximum of four line units and 12 channel units)

Additionally, the shelf provides termination points for alarms, power, metallic bypass pairs, auxiliary power pairs when using a doubler, and subscriber circuits (located on the backplane at the rear of the shelf - [Figure 2 on page 9](#)). The FCS-719 COT shelf provides four 25-pair male Amphenol connectors (P1, P2, P3, and P4) for the subscriber circuit connections.

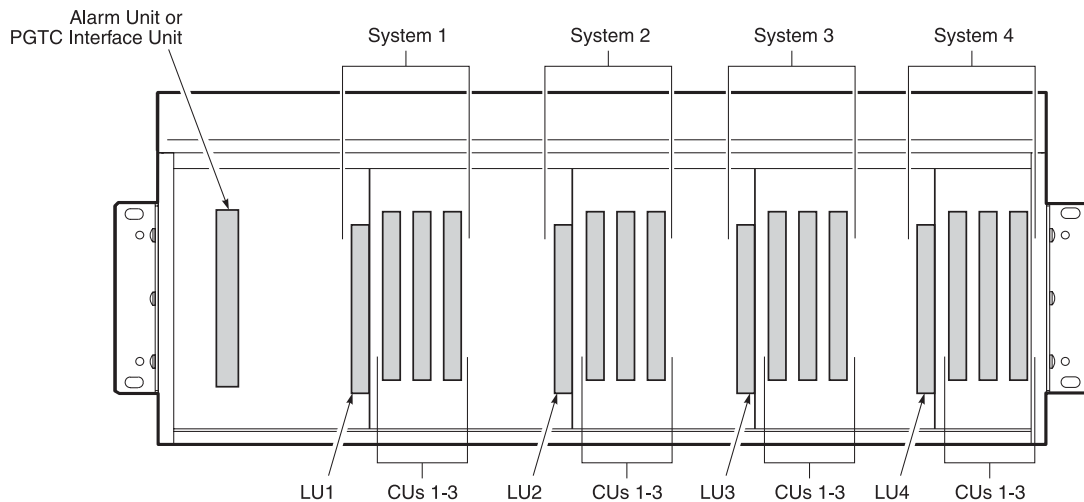

**Figure 1.** FCS-719 COT Shelf (Card-side, Front View)



**Use the FCS-719 COT 23-inch shelf only with a List 4x FRE-765 or FRE-86x Remote Terminal (RT) enclosure.**

Features of the PG-Flex FCS-719 COT shelf are:

- universal mounting brackets for installation into a 23-inch equipment bay
- wire-wrap connections for HDSL, alarms, metallic bypass pairs, and auxiliary power pairs (when using a doubler)
- split or single battery feed for shelf powering
- screw terminal connections for frame ground and Central Office (CO) battery
- DB-25 connector for Network Management Analysis (NMA) communications
- 25-pair Amphenol connectors for subscriber circuit connections
- 25-pair Amphenol connector for PGTC test interface

## SPECIFICATIONS

### Electrical Characteristics

Power	-48 Vdc CO battery
Composite Clock Termination	133 $\Omega$

### Environmental

Operating Temperature	-40° F to +150° F (-40° C to +65° C)
Operating Humidity	5% to 95% (non-condensing)
Operating Elevation	-200 feet to 13,000 feet (-60 m to 4,000 m)

### Compliance

NEBS	SR-3580 for Level 3
Human Safety	UL 1950 for Restricted Access
Emissions Radiation and Immunity	GR-1089-CORE for Class A Equipment

### Physical

Mounting	23-inch equipment bay using universal mounting brackets
Dimensions	
Height	8.75 in. (22.2 cm.)
Width	23.0 in. (58.4 cm.)
Depth	11.75 in. (29.8 cm.)
Weight	20.2 lbs. (9.2 kg.)

# FUNCTIONAL DESCRIPTION

This sections describes the FCS-719 operational capabilities and lists the connector pinouts on the backplane.

## OPERATIONAL CAPABILITIES

Each system (one line unit and one to four channel units) can support up to 24 subscriber channels. Each channel unit can provide four (4) or eight (8) channels, depending on the service offered. Services offered are:

- Plain Old Telephone Service (POTS)
- Integrated Services Digital Network (ISDN)



**A label on the FCS-719 shelf indicates numbering for the line and channel units. When the line units are a List 1 or 2, black numbers indicate sequential channel unit numbering 1 through 12. When the line units are List 3 or higher, blue numbers indicate channel unit numbering 1 through 3 for each of the four systems.**

[Table 1 on page 4](#) and [Table 2 on page 4](#) show how the FCS-719 utilizes channels, dependent on the channel unit (four or eight channels) and the type of subscriber service (POTS or ISDN) selected.

**Table 1.** COT Shelf Circuit Utilization

Channel Unit	Channel Unit Service Configurations		
	4-Channel POTS	8-Channel POTS	4-Channel ISDN
T/R 1	ckt 1	ckt 1	ckt 1
T/R 2	ckt 2	ckt 2	ckt 2
T/R 3	ckt 3	ckt 3	ckt 3
T/R 4	ckt 4	ckt 4	ckt 4
T/R 5	—	ckt 5	—
T/R 6	—	ckt 6	—
T/R 7	—	ckt 7	—
T/R 8	—	ckt 8	—

**Table 2.** Channel Unit Circuit Utilization\*

System 1			System 2			System 3			System 4		
CU 1 (CU 1)	CU 2 (CU 2)	CU 3 (CU 3)	CU 1 (CU 4)	CU 2 (CU 5)	CU 3 (CU 6)	CU 1 (CU 7)	CU 2 (CU 8)	CU 3 (CU 9)	CU 1 (CU 10)	CU 2 (CU 11)	CU 3 (CU 12)
ckt 1	ckt 1	ckt 1	ckt 1	ckt 1	ckt 1	ckt 1	ckt 1	ckt 1	ckt 1	ckt 1	ckt 1
ckt 2	ckt 2	ckt 2	ckt 2	ckt 2	ckt 2	ckt 2	ckt 2	ckt 2	ckt 2	ckt 2	ckt 2
ckt 3	ckt 3	ckt 3	ckt 3	ckt 3	ckt 3	ckt 3	ckt 3	ckt 3	ckt 3	ckt 3	ckt 3
ckt 4	ckt 4	ckt 4	ckt 4	ckt 4	ckt 4	ckt 4	ckt 4	ckt 4	ckt 4	ckt 4	ckt 4
ckt 5	ckt 5	ckt 5	ckt 5	ckt 5	ckt 5	ckt 5	ckt 5	ckt 5	ckt 5	ckt 5	ckt 5
ckt 6	ckt 6	ckt 6	ckt 6	ckt 6	ckt 6	ckt 6	ckt 6	ckt 6	ckt 6	ckt 6	ckt 6
ckt 7	ckt 7	ckt 7	ckt 7	ckt 7	ckt 7	ckt 7	ckt 7	ckt 7	ckt 7	ckt 7	ckt 7
ckt 8	ckt 8	ckt 8	ckt 8	ckt 8	ckt 8	ckt 8	ckt 8	ckt 8	ckt 8	ckt 8	ckt 8

(\*) The Channel Unit (CU) numbers on top (CU 1 through CU 3) show how the channel units are numbered when using a List 3 or higher line unit, relative to each system. The CU numbers in parentheses (CU 1 through CU 12) show how the channel units are numbered when using a List 1 or 2 line unit.

## BACKPLANE CONNECTIONS

Table 4 on page 6 through Table 6 on page 8 provides the connector pinouts located on the backplane for alarm or Pair Gain Test Controller (PGTC) interface unit, line unit, and channel unit connectors.

Table 7 on page 9 provides connectors and termination points located on the backplane for:

- CO power (-48V\_A, -48V\_B) and CO return (RTN\_A, RTN\_B)
- frame ground
- Local Area Network (LAN)
- data
- HDSL, test, composite clock, auxiliary power pairs, and external Alarm Cutoff (ACO) switch
- alarm or PGTC test interface
- subscriber lines with Amphenol connectors (P1, P2, P3, and P4)

Table 3 lists the FCS-719 connectors and where each is described in this practice (see Figure 2 on page 9 for connector locations).

**Table 3.** FCS-719 Card Connectors

Connector and Fuse	Go to	On
Alarm Unit or PGTC Interface Unit	Table 4	page 6
Line Unit Connectors (Systems 1 thru 4)	Table 5	page 7
Channel Unit Connectors (Systems 1 thru 4)	Table 6	page 8



**Use the Information in Table 4 on page 6 through Table 6 on page 8 for diagnostic and troubleshooting procedures under the direction of an authorized ADC technical support representative.**

**Table 4.** Alarm Unit or PGTC Interface Unit Connector

J1-C Pin	J1-C Signal	J1-B Pin	J1-B Signal	J1-A Pin	J1-A Signal
1	LAN	1	LGND (CDS)	1	NMA_CD
2	*CRIT_VIS_NO	2	INHIBIT	2	*CRIT_VIS_COM
3	PGTC_TIP1	3	SLEEVE1	3	TESTIN-T_1
4	PGTC_RING1	4	SLEEVE2	4	TESTIN-R_1
5	PGTC_TIP2	5	SLEEVE3	5	TESTIN-T_2
6	PGTC_RING2	6	SLEEVE4	6	TESTIN-R_2
7	PGTC_TIP3	7	OH1	7	TESTIN-T_3
8	PGTC_RING3	8	OH2	8	TESTIN-R_3
9	PGTC_TIP4	9	OH3	9	TESTOUT-T_1
10	PGTC_RING4	10	OH4	10	TESTOUT-R_1
11	N/C (BURN-IN)	11	PROCEED1	11	TESTOUT-T_2
12	LOCK1	12	PROCEED2	12	TESTOUT-R_2
13	LOCK2	13	PROCEED3	13	TESTOUT-T_3
14	LOCK3	14	PROCEED4	14	TESTOUT-R_3
15	LOCK4	15	SEIZE	15	TESTOUT-T_4
16	TMAJ	16	SEZBY	16	TESTOUT-R_4
17	+5_2	17	TSTALM	17	+5_1
18	NMA_TX	18	NMA_RX	18	NMA_DTR
19	NMA_DSR	19	NMA_TCLK	19	NMA_RCLK
20	NMA_BUS_1	20	NMA_BUS_2	20	TESTIN-T_4
21	NMA_BUS_3	21	NMA_BUS_4	21	TESTIN-R_4
22	CC1_TIP	22	CC1_RING	22	EXT_ACO
23	CC2_TIP	23	CC2_RING	23	8KHZ_CC
24	SHELF_ID_NO	24	SHELF_ID_COM	24	SHELF_ID_NC
25	MAJ_AUD_NO	25	MAJ_AUD_COM	25	MAJ_AUD_NC
26	MAJ_VIS_NO	26	MAJ_VIS_COM	26	MAJ_VIS_NC
27	MIN_AUD_NO	27	MIN_AUD_COM	27	MIN_AUD_NC
28	MIN_VIS_NO	28	MIN_VIS_COM	28	MIN_VIS_NC
29	FUSEALARM	29	MAJORALARM	29	MINORALARM
30	-48V_B (BATT)	30	N/C	30	-48V_A (BATT)
31	BATT_RTN	31	BATT_RTN	31	BATT_RTN
32	PROTGND	32	GND	32	GND

\* When using an FPI-829 List 3 PGTC Interface Unit



**Table 5.** Line Unit Connectors

<u>System</u>		<u>Line Unit</u>		<u>Connector</u>	
1		1		J2	
2		2		J7	
3		3		J12	
4		4		J17	
Pin	Signal*	Pin	Signal*		
1	PROTGND	2	PROTGND		
3	N/C	4	N/C		
5	HDSL_TIP1_EX_n	6	HDSL_TIP2_EX_n		
7	HDSL_RING1_EX_n	8	HDSL_RING2_EX_n		
9	N/C	10	N/C		
11	BATT_RTN	12	BATT_RTN		
13	-48_n	14	-48_n		
15	BATT_x†	16	BATT_x†		
17	8KHZ_CC	18	N/C (BURN-IN)		
19	TSYNC_n	20	TSIG_n		
21	TCLK_n	22	TSER_n		
23	GND	24	RSYNC_n		
25	RSIG_n	26	RCLK_n		
27	RSER_n	28	GND		
29	SDA_n	30	CSYNC_n		
31	FUSEALARM	32	SCL_n		
33	+5_n	34	+5_n		
35	GND	36	GND		
37	-5_n	38	-5_n		
39	NMA_BUS_n	40	CID3		
41	CID2	42	CID1		
43	MAJORALARM	44	MINORALARM		
45	TESTIN-T_n	46	TESTIN-R_n		
47	TESTOUT-T_n	48	TESTOUT-R_n		
49	N/C	50	N/C		
51	BYPASS-T_n	52	BYPASS-R_n		
53	HDSL TIP1_n	54	HDSL TIP2_n		
55	HDSL RING1_n	56	HDSL RING2_n		
57	N/C	58	N/C		
59	PROTGND	60	PROTGND		

\* Where *n* is 1, 2, 3, or 4 for Systems 1, 2, 3, or 4 respectively† Where *x* is A for Systems 1 and 2 and B for Systems 3 and 4

**Table 6. Channel Unit Connector Pinouts for Systems 1, 2, 3, and 4**

System	Channel Unit	Connector	System	Channel Unit	Connector	System	Channel Unit	Connector
1	1	J3	1	2	J4	1	3	J5
2	1 (4)*	J8	2	2 (5)*	J9	2	3 (6)*	J10
3	1 (7)*	J13	3	2 (8)*	J14	3	3 (9)*	J15
4	1 (10)*	J18	4	2 (11)*	J19	4	3 (12)*	J20

Pin	Signal	Pin	Signal	Pin	Signal	Pin	Signal	Pin	Signal	Pin	Signal
1	PROTGND	2	PROTGND	1	PROTGND	2	PROTGND	1	PROTGND	2	PROTGND
3	TIP05_n	4	RING05_n	3	TIP05_n	4	RING05_n	3	TIP05_n	4	RING05_n
5	TIP06_n	6	RING06_n	5	TIP06_n	6	RING06_n	5	TIP06_n	6	RING06_n
7	TIP07_n	8	RING07_n	7	TIP07_n	8	RING07_n	7	TIP07_n	8	RING07_n
9	TIP08_n	10	RING08_n	9	TIP08_n	10	RING08_n	9	TIP08_n	10	RING08_n
11	BATT_RTN	12	BATT_RTN	11	BATT_RTN	12	BATT_RTN	11	BATT_RTN	12	BATT_RTN
13	-48_n	14	-48_n	13	-48_n	14	-48_n	13	-48_n	14	-48_n
15	-48V_x‡ (BATT)	16	-48V_x‡ (BATT)	15	-48V_x‡ (BATT)	16	-48V_x‡ (BATT)	15	-48V_x‡ (BATT)	16	-48V_x‡ (BATT)
17	8KHZ_CC	18	N/C (BURN-IN)	17	8KHZ_CC	18	N/C (BURN-IN)	17	8KHZ_CC	18	N/C (BURN-IN)
19	TSYNC_n	20	TSIG_n	19	TSYNC_n	20	TSIG_n	19	TSYNC_n	20	TSIG_n
21	TCLK_n	22	TSER_n	21	TCLK_n	22	TSER_n	21	TCLK_n	22	TSER_n
23	GND	24	RSYNC_n	23	GND	24	RSYNC_n	23	GND	24	RSYNC_n
25	RSIG_n	26	RCLK_n	25	RSIG_n	26	RCLK_n	25	RSIG_n	26	RCLK_n
27	RSER_n	28	GND	27	RSER_n	28	GND	27	RSER_n	28	GND
29	SDA_n	30	CSYNC_n	29	SDA_n	30	CSYNC_n	29	SDA_n	30	CSYNC_n
31	N/C	32	SCL_n	31	N/C	32	SCL_n	31	N/C	32	SCL_n
33	+5_n	34	+5_n	33	+5_n	34	+5_n	33	+5_n	34	+5_n
35	GND	36	GND	35	GND	36	GND	35	GND	36	GND
37	-5_n	38	-5_n	37	-5_n	38	-5_n	37	-5_n	38	-5_n
39	N/C	40	GND (CID3)	39	N/C	40	GND (CID3)	39	N/C	40	GND (CID3)
41	GND (CID2)	42	GND (CID1)	41	GND (CID2)	42	GND (CID1)	41	GND (CID2)	42	GND (CID1)
43	GND (CID0)	44	N/C	43	GND (CID0)	44	N/C	43	GND (CID0)	44	N/C
45	TESTIN-T_n	46	TESTIN-R_n	45	TESTIN-T_n	46	TESTIN-R_n	45	TESTIN-T_n	46	TESTIN-R_n
47	GND	48	GND	47	GND	48	GND	47	GND	48	GND
49	TESTOUT-T_n	50	TESTOUT-R_n	49	TESTOUT-T_n	50	TESTOUT-R_n	49	TESTOUT-T_n	50	TESTOUT-R_n
51	TIP01_n	52	RING01_n	51	TIP01_n	52	RING01_n	51	TIP01_n	52	RING01_n
53	TIP02_n	54	RING02_n	53	TIP02_n	54	RING02_n	53	TIP02_n	54	RING02_n
55	TIP03_n	56	RING03_n	55	TIP03_n	56	RING03_n	55	TIP03_n	56	RING03_n
57	TIP04_n	58	RING04_n	57	TIP04_n	58	RING04_n	57	TIP04_n	58	RING04_n
59	PROTGND	60	PROTGND	59	PROTGND	60	PROTGND	59	PROTGND	60	PROTGND

\* Channel Unit numbers (CU 1 through CU 3) show how the channel units are numbered when using a List 3 or higher line unit, relative to each system. Channel Unit numbers in parenthesis (CU 1 through CU 12) show how the channel units are numbered when using a List 1 or List 2 line unit.

† Where *n* is 1 for system 1, 2 for system 2, 3 for system 3, or 4 for system 4

‡ Where *x* is A for systems 1 and 2, and B for systems 3 and 4

Table 7 lists the FCS-719 COT shelf backplane connectors and where each is described in this practice. (Refer to Figure 2 for connector locations and refer to Figure 10 on page 21 for alarm terminations).

**Table 7. FCS-719 COT Shelf Backplane Connectors**

Connector and Fuse	Go to	On
CO Battery; TB1 (-48V_A) and TB2 (-48V_B), CO Battery return; TB3 (RTN_B) and TB4 (RTN_A), and Frame Ground (G1)	Table 8	page 10
LAN (J6)	Table 9	page 10
Data (J21)	Table 10	page 10
HDSL, Auxiliary Power Pairs, Composite Clock, Bypass Pair, Channel Unit Test, Frame Ground, External ACO (not shown in Figure 2)	Table 12	page 17
Alarm Terminations	Table 13	page 22
Subscriber Amphenol Terminations (P1, P2, P3, and P4)	Table 15	page 24
PGTC (P26)	Table 16	page 26

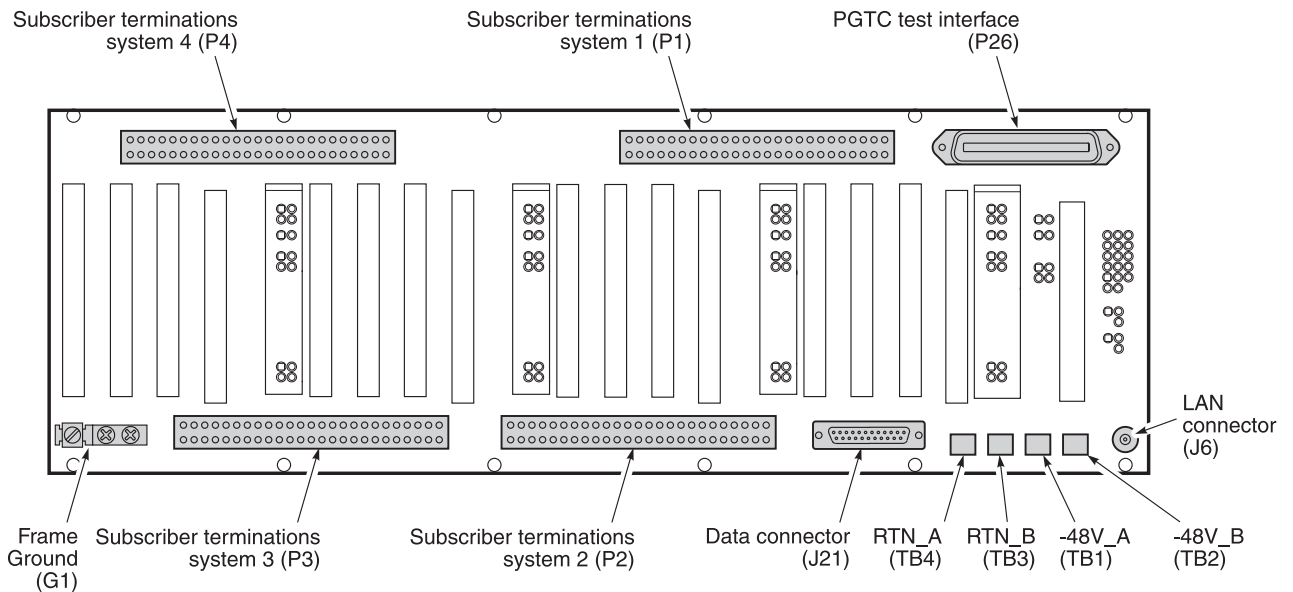

**Figure 2. FCS-719 COT Shelf Backplane**

**Table 8.** *Battery, CO Battery Return, and Frame Ground*

Connector	Type	Function
TB1	Screw	Battery (-48V_A) for systems 1 and 2
TB2	Screw	Battery (-48V_B) for systems 3 and 4
TB3	Screw	CO battery return B (RTN_B)
TB4	Screw	CO battery return A (RTN_A)
G1	Screw	Frame Ground (Protection Ground)

**Table 9.** *LAN Connector*

Connector	Type	Function
J6	BNC	(Not currently used)

**Table 10.** *DTE Connector (J21) Pinouts*

DB-25 (F) Pins	Signal
1	Frame Ground (GND)
2	Transmit Data
3	Receive Data
6	Data Set Ready
7	Signal Common (GND)
8	Carrier Detect
15	Transmit Clock
17	Receive Clock
20	Data Terminal Ready

# INSTALLATION AND TEST

This section provides procedures for unpacking, HDSL pre-provisioning, mounting, and wiring for the FCS-719 COT shelf.

## UNPACKING

Upon receipt of the equipment:

- 1 Unpack each container and visually inspect it for signs of damage. If the equipment has been damaged in transit, immediately report the extent of damage to the transportation company and to ADC. Order replacement equipment if necessary.
- 2 Check the contents against the packing list to ensure complete and accurate shipment. If the shipment is short or irregular, contact ADC as described in “Returns” on page 28. If you must store the equipment for a prolonged period, store the equipment in its original container.

## SELECTING HDSL LINES

HDSL transmission uses two copper pairs connected between the FCS-719 COT shelf and RT enclosure. The wire pairs should have identical electrical make-ups. Differences in total wire length, wire gauge, bridge taps, and exposure to crosstalk should be kept to a minimum. Pair isolation, (Tip-Ring, Tip-Ground, and Ring-Ground) must be  $\geq 100 \text{ k}\Omega$ .

The wire pairs from the FCS-719 COT shelf to the RT enclosure must meet the following guidelines:

- nonloaded cable only
- multigauge is restricted to two gauge changes, except for stubbing or fusing
- total bridge taps may not exceed 2.5 kft. No single bridge tap may exceed 2.0 kft

The distance limitation for HDSL transmission is based on a maximum signal attenuation of 35 dB. Since signal attenuation decreases as cable size increases, the larger the gauge (19 AWG vs. 26 AWG), the greater the distance between the FCS-719 COT shelf and the RT enclosure. Table 11 identifies these distances (at a cable temperature of 68°F):

**Table 11.** 12/24 Channel HDSL Transmission Distances

Gauge	Loop Length	Resistance
19 AWG 0.9 mm	22.8 kft 7.0 km	367 $\Omega$
22 AWG 0.6 mm	16.1 kft 4.9 km	521 $\Omega$
24 AWG 0.5 mm	12.3 kft 3.7 km	638 $\Omega$
26 AWG 0.4 mm	9.0 kft 2.7 km	750 $\Omega$

## MOUNTING

The FCS-719 COT shelf mounts in a standard 23-inch CO equipment bay. The shelf has a mounting height requirement of 8.75 inches.

- 1 Align the shelf universal mounting brackets with the four vertical mounting holes (see [Figure 3](#)).
- 2 Install the mounting screws (provided) and secure to the CO equipment bay.

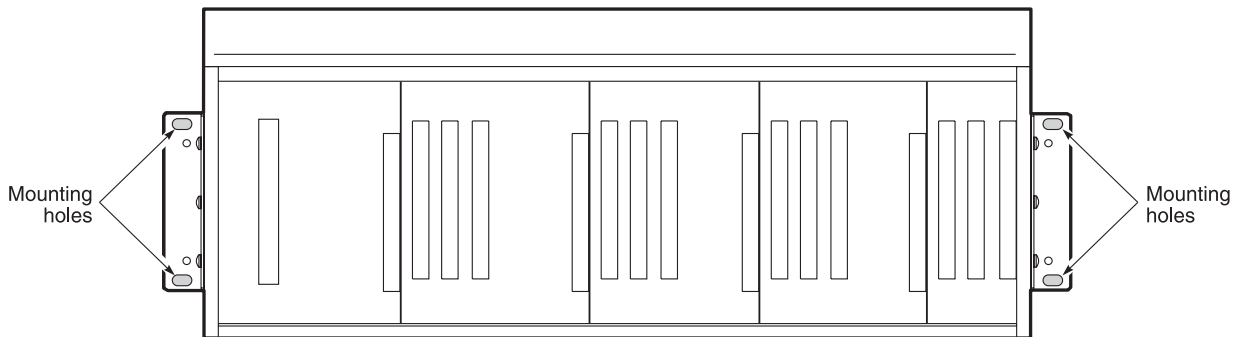

*Figure 3. Mounting the FCS-719 COT Shelf*

## WIRING

Connect wiring to the FCS-719 as described in the following sections. All wiring to the COT shelf is performed on the back side of the backplane.



**Follow the provisions of the current edition of the National Electric Code for external wiring to the PG-Flex product(s).**

**Use 12 AWG or larger wire (or multiple wires of a smaller gauge) to ensure good power connections to PG-Flex.**

### Before You Begin

- 1 Remove the clear Plexiglas™ cover from the back side of the COT shelf.
- 2 Remove the fuses in the equipment bay fuse panel for the circuits where the PG-Flex CO battery wires will be terminated.



**Follow local grounding practices to ensure a good frame ground connection to the PG-Flex. This frame grounding is required for secondary voltage protection of the PG-Flex equipment.**

## Connect the Frame Ground



CO battery return (RTN\_A, RTN\_B) is separate from frame ground in the PG-Flex equipment.

CKT GND and CO battery return are connected inside the PG-Flex line unit but are not connected on the backplane.

Follow the instructions below and refer to [Figure 4](#) to connect the frame ground.

- 1 Connect one end of the frame ground wire to the grounding lug G1 (Frame Ground).
- 2 Connect the other end of the frame ground wire to the CO ground termination point.



The minimum frame ground wire size is 6 AWG.

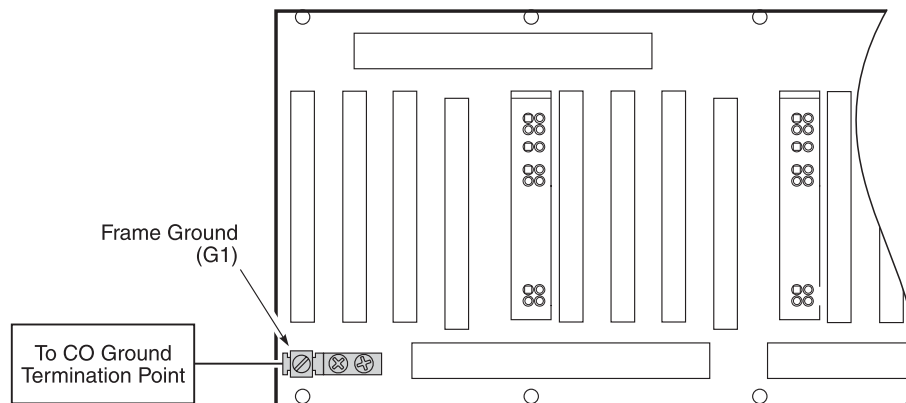

**Figure 4.** Connecting the Frame Ground (Protection Ground)

## Connect the CO Battery

The FCS-719 COT shelf can be powered from a single battery feed or from a split battery feed. Refer to [Figure 5](#) for battery termination points.



Use 12 AWG or larger wire (or multiple wires of a smaller gauge) to ensure good power connections to the PG-Flex system.

### Single Battery Feed

For a single battery feed do the following ([Figure 5](#)):

- 1 Verify the jumper is installed between TB1 and TB2.
- 2 Connect the wire from CO battery return to TB4 (RTN\_A) termination point.
- 3 Connect the CO battery wires from TB1 and TB4 on the COT shelf to the equipment bay fuse panel termination points.

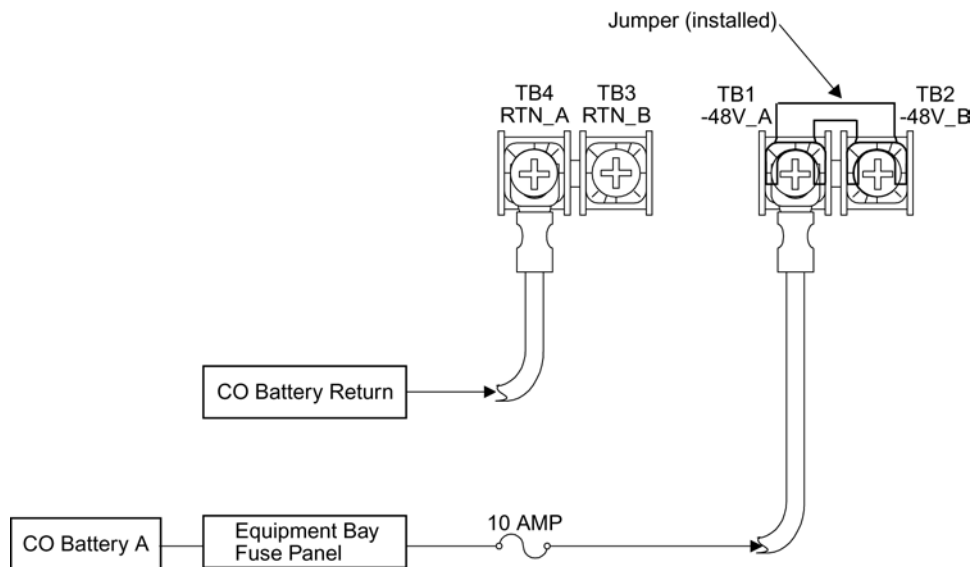

**Figure 5.** Connecting a Single Battery Feed



## Split Battery Feed

For a split battery feed do the following (Figure 6):



When using a split battery feed, -48V\_A provides the battery feed for system 1 and 2, and -48V\_B provides the battery feed for system 3 and 4.

- 1 Remove and discard the jumper between TB1 and TB2.
- 2 Connect the wire from CO battery A to TB1 (-48V\_A) termination point.
- 3 Connect the wire from CO battery B to TB2 (-48V\_B) termination point.
- 4 Connect the wire from CO battery return A to TB4 (RTN\_A) termination point.
- 5 Connect the wire from CO battery return B to TB3 (RTN\_B) termination point.
- 6 Connect the CO battery return wire from TB1, TB2, TB3, and TB4 on the COT shelf to the equipment bay fuse panel termination points.



When the FCS-719 COT shelf is configured for a split battery feed, insert a 5 amp fuse into the equipment bay fuse panel for each circuit where the PG-Flex CO battery wires are terminated.

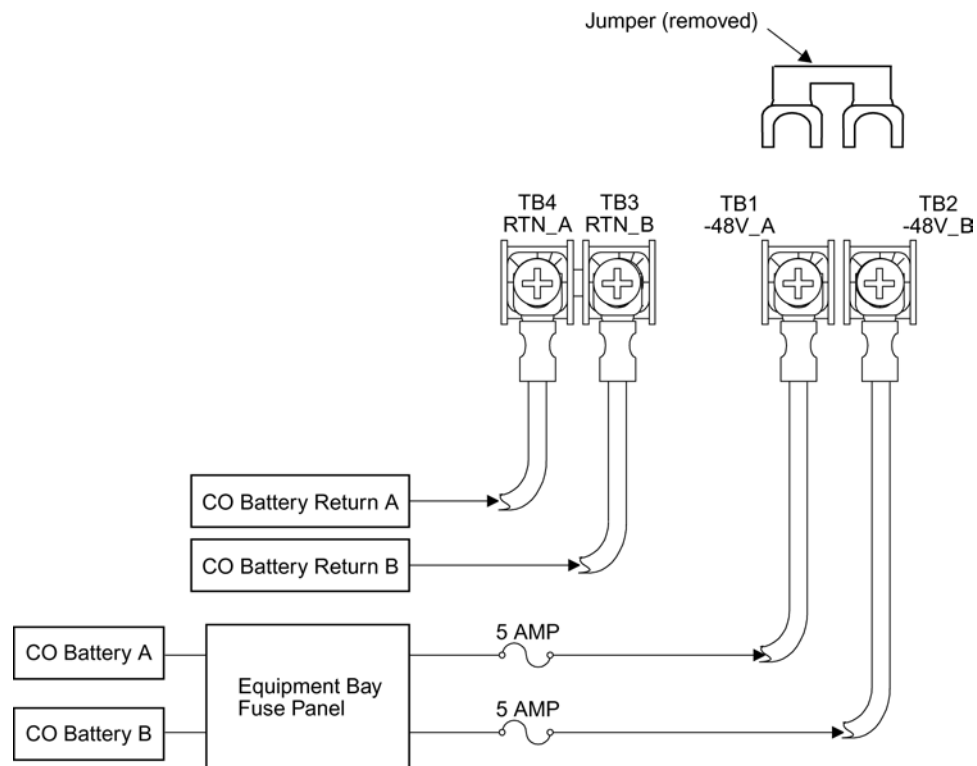

**Figure 6.** Connecting a Split Battery Feed

## HDSL Pairs

Connect the HDSL pair as shown in [Figure 7](#). Note that  $n$  is 1 for System 1, 2 for System 2, 3 for System 3, and 4 for System 4. Refer to [Table 12 on page 17](#) for HDSL terminations and functions.

- 1 Connect the HDSL Pair #1 onto wire-wrap pins HDSL\_  $n$  \_T1 (Tip) and HDSL\_  $n$  \_R1 (Ring) on the COT shelf for system  $n$ .
- 2 Connect the HDSL Pair #2 onto wire-wrap pins HDSL\_  $n$  \_T2 (Tip) and HDSL\_  $n$  \_R2 (Ring) on the COT shelf for system  $n$ .
- 3 Repeat steps 1 and 2 for each system installed.



For ease of identification and added safety, install the red vinyl caps (included) over the HDSL wire-wrap pins.

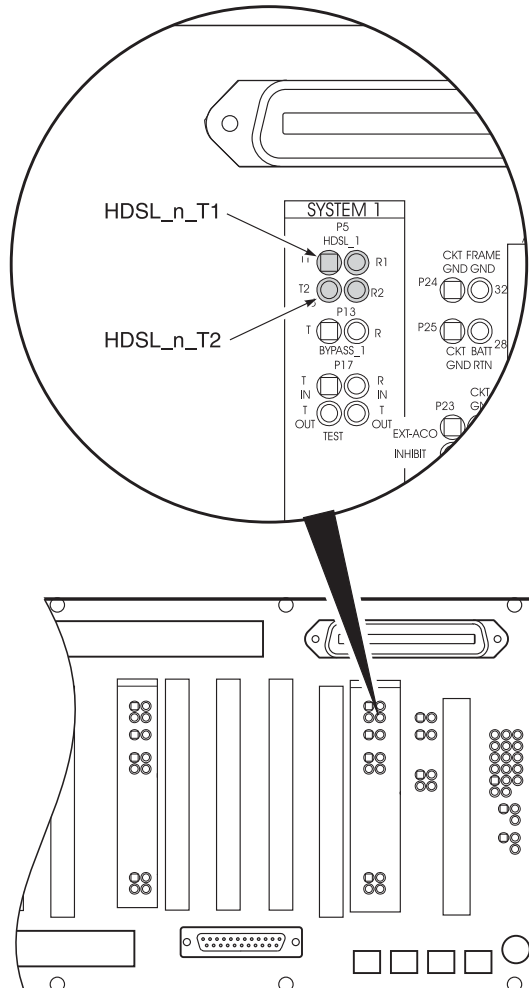

**Figure 7.** Connecting the HDSL Lines

**Table 12.** HDSL, Test, And Miscellaneous Connectors

System*	Connector	Type	Function
System <i>n</i>	HDSL_ <i>n</i> _T1 HDSL_ <i>n</i> _R1	.045 in. Wire-wrap	Tip and Ring terminations for HDSL Pair #1 of System <i>n</i> to Remote Terminal <i>n</i> . The HDSL termination point for each system is: P5 for system 1, P6 for system 2, P7 for system 3, and P8 for system 4. -130 Vdc is simplexed on this line for powering the Remote Terminal.
System <i>n</i>	HDSL_ <i>n</i> _T2 HDSL_ <i>n</i> _R2	.045 in. Wire-wrap	Tip and Ring terminations for HDSL Pair #2 of System <i>n</i> to Remote Terminal <i>n</i> . The HDSL termination point for each system is: P5 for system 1, P6 for system 2, P7 for system 3, and P8 for system 4. +130 Vdc is simplexed on this line for powering the Remote Terminal.
System <i>n</i>	PWR_OUT T1 PWR_OUT R1	.045 in. Wire-wrap	System <i>n</i> auxiliary Power Pair #1. Used for auxiliary power to the RT when using a PG-Flex doubler unit. The auxiliary power termination point for each system is: P9 for system 1, P10 for system 2, P11 for system 3 and P12 for system 4.
System <i>n</i>	PWR_OUT T2 PWR_OUT R2	.045 in. Wire-wrap	System <i>n</i> auxiliary Power Pair #2. Used for auxiliary power to the RT when using a PG-Flex doubler unit. The auxiliary power termination point for each system is: P9 for system 1, P10 for system 2, P11 for system 3 and P12 for system 4.
System <i>n</i>	BYPASS_ <i>n</i> _T BYPASS_ <i>n</i> _R	.045 in. Wire-wrap	Termination for the metallic bypass pair into COT System <i>n</i> from RT <i>n</i> . The termination point for each system is: P13 for system 1, P14 for system 2, P15 for system 3, P16, for system 4.
System <i>n</i>	TEST_ <i>n</i> _T IN TEST_ <i>n</i> _R IN	.045 in. Wire-wrap	Test connection looking toward the CO switch of the selected subscriber for System <i>n</i> . This connection must be set up through the PG-Flex Craft port. The termination point for each system is: P17 for system 1, P18 for system 2, P19 for system 3, and P20 for system 4.
System <i>n</i>	TEST_ <i>n</i> _T OUT TEST_ <i>n</i> _R OUT	.045 in. Wire-wrap	Test connection looking toward the subscriber of the selected circuit for System <i>n</i> . This connection must be set up through the PG-Flex Craft port. The termination point for each system is: P17 for system 1, P18 for system 2, P19 for system 3, and P20 for system 4.
	CC1_TIP CC1_RING CC1_TERM	.045 in. Wire-wrap	Composite Clock #1 used for primary synchronization to CO timing. These pins (P21) can be cascaded. Terminate on the CC1_TERM pins on the last shelf in the cascade. A 133Ω termination resistor (provided on the FCS-719 COT shelf backplane) is placed across CC1_TIP and CC1_RING by installing a jumper between CC1_TIP and CC1_TERM.
	CC2_TIP CC2_RING CC2_TERM	.045 in. Wire-wrap	Composite Clock #2 used for secondary synchronization to CO timing. These pins (P27) can be cascaded. Terminate on the CC2_TERM pins on the last shelf in the cascade. A 133Ω termination resistor (provided on the FCS-719 COT shelf backplane) is placed across CC2_TIP and CC2_RING by installing a jumper between CC2_TIP and CC2_TERM.
	FRAME_GND CKT_GND	.045 in. Wire-wrap	Frame ground is isolated from CO battery ground in PG-Flex.
	EXT_ACO CKT_GND	.045 in. Wire-wrap	External Alarm Cutoff (P23, pins 1 and 2). A momentary connection between EXT_ACO and CKT_GND (circuit ground) silences the PG-Flex audible alarms.
	INHIBIT†	.045 in. Wire-wrap	When a PGTC interface card is installed, the PGTC inhibit connection pin is used to indicate whether a shared bypass pair is available or is currently in use by another system.
	BAT RTN CKT GND	.045 in. Wire-wrap	CO battery return. This is isolated from frame ground in PG-Flex. The BAT RTN and CKT GND wire-wrap posts are jumpered together on the FCS-719 COT shelf backplane.

\* Where n is 1 on System 1, 2 on System 2, 3 on System 3, and 4 on System 4.

† Connecting the inhibit pins of multiple PG-Flex systems that are sharing the same bypass pair prevents other systems from attempting to use the bypass pair when it is currently being used by another system. The inhibit pin is grounded when the bypass pair is in use, and -48 Vdc when the bypass pair is inactive.

## Bypass Pairs

If subscriber drop testing is required, connect the metallic bypass pairs from the RT enclosure to the COT shelf backplane wire-wrap pins as shown in [Figure 8 on page 19](#) (refer to [Table 12 on page 17](#) for bypass pair terminations and functions). Bypass pairs can be connected directly to each PG-Flex system, or shared between other PG-Flex systems by cascading the pairs between other systems.

### Directly Connected Bypass Pairs

To connect the bypass pairs directly to each system, do the following:

- 1 For System 1, connect the metallic bypass pair from the Main Distribution Frame (MDF) to wire-wrap posts `BYPASS_1_T` (Tip) and `BYPASS_1_R` (Ring) on the COT shelf (see [Figure 8 on page 19](#)).
- 2 Repeat step 1 for Systems 2, 3 and 4 using the following bypass pin pairs:
  - `BYPASS_2_T`, `BYPASS_2_R` for system 2
  - `BYPASS_3_T`, `BYPASS_3_R` for system 3
  - `BYPASS_4_T`, `BYPASS_4_R` for system 4

### Shared Bypass Pairs

To share bypass pairs between PG-Flex systems, do the following:



**When metallic bypass pairs are shared between PG-Flex shelves or to other Digital Loop Carriers (DLC) systems, the INHIBIT lead must be connected between each shelf sharing the bypass pairs.**

- 1 For System *n*, connect the metallic bypass pair from the main distribution frame (MDF) to wire-wrap posts `BYPASS_n_T` (Tip) and `BYPASS_n_R` (Ring) on the backplane of the first COT shelf sharing the bypass pair (see [Figure 8 on page 19](#)).
- 2 Connect the metallic bypass pair `BYPASS_n_T` and `BYPASS_n_R` on the first COT shelf in the cascade to the next bypass pair terminations on the next COT shelf sharing the bypass pair.

- 3 Connect the INHIBIT line from the one COT shelf in the system to the next COT shelf sharing the metallic bypass pair.
- 4 Repeat [Step 2](#) and [Step 3](#) for each PG-Flex system in the cascade.



The INHIBIT line is used only when the metallic bypass pair is shared between two or more systems installed in more than one shelf.

An FPI-729 or FPI-829 PGTC interface unit or FAU-728 List 2 alarm unit must be installed in each FCS-719 COT shelf where the INHIBIT line is used.

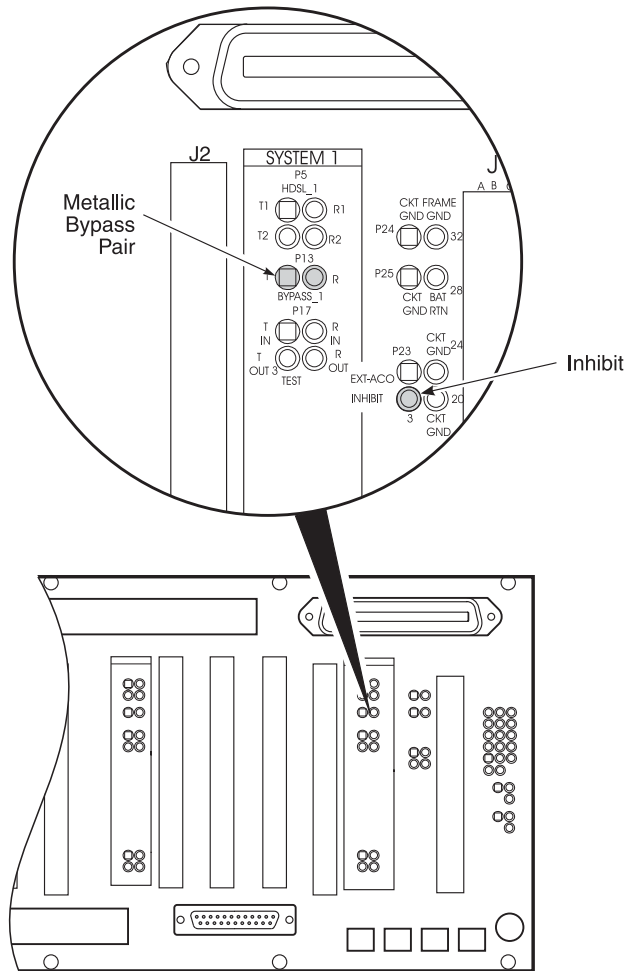

**Figure 8.** Connecting the Metallic Bypass Pair

## Auxiliary Power Pairs

For each doubler installed in the HDSL circuit, two auxiliary power pairs are required between the CO and RT. Wire the auxiliary power pairs to the COT shelf (Figure 9) as follows:

- 1 Wire-wrap auxiliary power pair 1 to PWR\_1\_T1 (Tip) and PWR\_1\_R1 (Ring) for system 1.
- 2 Wire-wrap auxiliary power pair 2 to PWR\_2\_T2 (Tip) and PWR\_2\_R2 (Ring) for system 1.
- 3 Repeat steps 1 and 2 when required for systems 2, 3, and 4.



For ease of identification and added safety, install the red vinyl caps (included) over the auxiliary power pair wire-wrap pins.

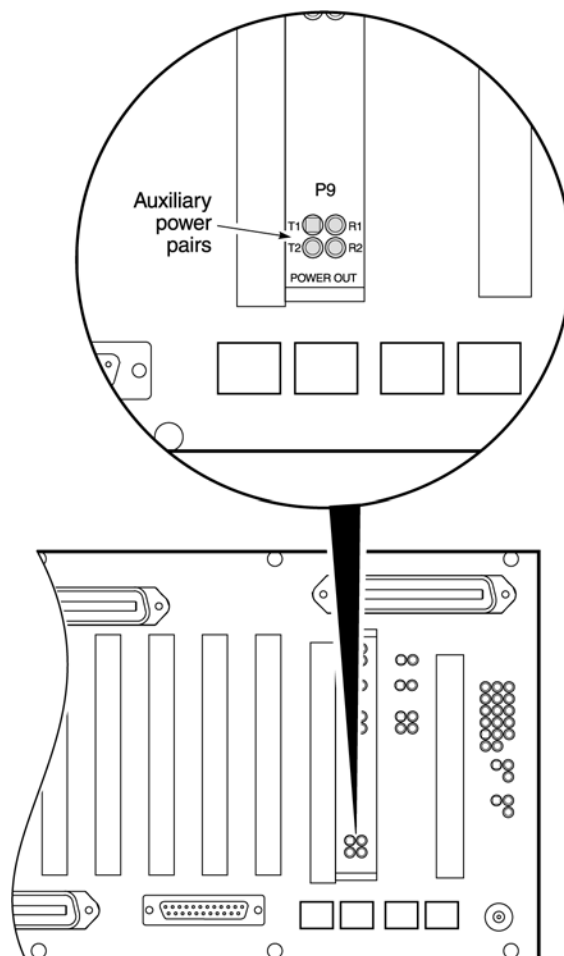

**Figure 9.** Connecting the Composite Clock and Alarms

## Composite Clock

A composite clock is required when the PG-Flex system provides digital services (i.e., ISDN). Connect the composite clock as shown in Figure 10 (refer to Table 12 on page 17 for composite clock terminations and functions). You can cascade the composite clock to other PG-Flex shelves. When cascading the composite clock to other PG-Flex shelves, terminate only on the last shelf in the cascade.



**If the composite clock is connected, it must be terminated by connecting a jumper from CC1\_TIP to CC1\_TERM wire-wrap pins, and from CC2\_TIP to CC2\_TERM wire-wrap pins on the last shelf in the cascade.**

- 1 Connect the composite clock leads from the primary master clock source in the CO to CC1\_TIP and CC1\_RING wire-wrap pins on the backplane.
- 2 Connect the composite clock leads from the secondary master clock source in the CO to CC2\_TIP and CC2\_RING wire-wrap pins on the backplane.
- 3 When cascading the composite clock to other PG-Flex shelves, install a jumper from CC1\_TERM to CC1\_TIP and from CC2\_TERM to CC2\_TIP only on the last shelf in the cascade.

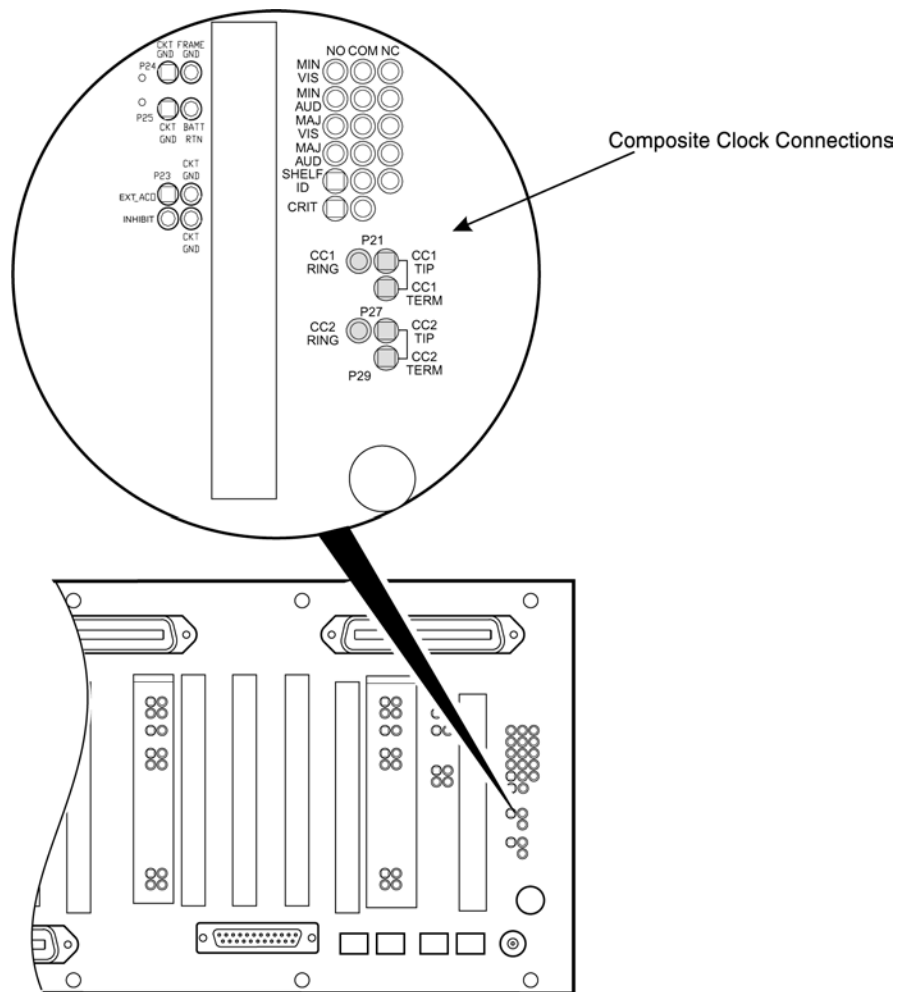

**Figure 10.** Connecting the Composite Clock and Alarms

## Alarms

If external audible and visual alarm indications are required, connect the audible and visual alarm leads from the CO alarm panel to the FCS-719 COT shelf alarm contacts (P22, see [Figure 10 on page 21](#)) according to local practice. Refer to [Table 13](#) for alarm terminations and functions.

A momentary connection between EXT\_ACO (P23, pin 1) and CKT\_GRD (P23, pin 2) will silence the PG-Flex audible alarms ([Figure 10 on page 21](#) and [Table 12 on page 17](#)).

The following sections describe how to connect the CO alarm panel to the FCS-719 COT shelf alarm contacts.

### Alarm Terminations for FPI-729 or FAU-728 List 2

Refer to [Table 13](#) for alarm terminations for the FPI-729 or FAU-728 List 2.

**Table 13.** Alarm Terminations for FPI-729 or FAU-728 List 2

Posts	Contact† Post NO*	Contact† Post COM*	Contact† Post NC*	FUNCTION
SHELF_ID	SHELF_ID NO	SHELF_ID COM	SHELF_ID NC	Shelf ID indicates a major or minor shelf alarm is active.
MAJ_AUD	MAJ_AUD NO	MAJ_AUD COM	MAJ_AUD NC	Indicates a major alarm. The alarm can be silenced using the ACO button. This contact is connected to the major alarm audible indicator of the CO alarm system.
MAJ_VIS	MAJ_VIS NO	MAJ_VIS COM	MAJ_VIS NC	Indicates a major alarm. This alarm cannot be disabled. This contact is connected to the major alarm visual indicator of the CO alarm system.
MIN_AUD	MIN_AUD NO	MIN_AUD COM	MIN_AUD NC	Indicates a minor alarm. The alarm can be silenced using the ACO button. This contact is connected to the minor alarm audible indicator of the CO alarm system.
MIN_VIS	MIN_VIS NO	MIN_VIS COM	MIN_VIS NC	Indicates a minor alarm. This alarm cannot be disabled. This contact is connected to the minor alarm visual indicator of the CO alarm system.
CRIT				Not currently supported.

\* For the relay contacts, NO is normally opened, NC is normally closed, and COM is common.  
† All relays provide form "C" contacts.



## Alarm Terminations for FPI-829

When using a PGTC Interface unit (FPI-829) in the FCS-719 COT shelf, the alarm contacts change functionality to support the FPI-829. Refer to [Table 14](#) for alarm terminations for the FPI-829.

**Table 14.** Alarm Terminations for FPI-829

Alarm Type	Contact† Post NO*	Contact† Post COM*	Contact† Post NC*	FUNCTION
SHELF_ID	SHELF_ID NO	SHELF_ID COM	Not Applicable	Shelf ID indicates a major or minor shelf alarm is active.
MAJ_AUD	MAJ_AUD NO	MAJ_AUD COM	Not Applicable	Indicates a major alarm. The alarm can be silenced using the ACO button. This contact is connected to the major alarm audible indicator of the CO alarm system.
MAJ_VIS	MAJ_VIS NO	MAJ_VIS COM	Not Applicable	Indicates a major alarm. This alarm cannot be disabled. This contact is connected to the major alarm visual indicator of the CO alarm system.
MIN_AUD	MIN_AUD NO	MIN_AUD COM	Not Applicable	Indicates a minor alarm. The alarm can be silenced using the ACO button. This contact is connected to the minor alarm audible indicator of the CO alarm system.
MIN_VIS	MIN_VIS NO	MIN_VIS COM	Not Applicable	Indicates a minor alarm. This alarm cannot be disabled. This contact is connected to the minor alarm visual indicator of the CO alarm system.
CRIT	CRIT NO	CRIT COM	Not Applicable	Indicates a critical visual alarm. This alarm cannot be disabled. This contact is connected to the critical alarm visual indicator of the CO alarm system.
System 1 Alarm	MIN_VIS NC	SHELF_ID NC	Not Applicable	Indicates a major or minor alarm associated with System 1 has been generated by the CO alarm system.
System 2 Alarm	MIN_AUD NC	SHELF_ID NC	Not Applicable	Indicates a major or minor alarm associated with System 2 has been generated by the CO alarm system.
System 3 Alarm	MAJ_VIS NC	SHELF_ID NC	Not Applicable	Indicates a major or minor alarm associated with System 3 has been generated by the CO alarm system.
System 4 Alarm	MAJ_AUD NC	SHELF_ID NC	Not Applicable	Indicates a major or minor alarm associated with System 4 has been generated by the CO alarm system.

\* For the relay contacts, NO is normally opened, NC is normally closed, and COM is common.

† All relays provide form “A” contacts.

## Subscriber Lines

Connect the subscriber circuits to the appropriate Amphenol subscriber termination (refer to [Figure 2 on page 9](#) for termination locations):

- 1 For PG-Flex system 1, connect the CO subscriber line to P1 using a 25-pair Amphenol cable. Refer to [Table 15 on page 24](#) for system subscriber terminations.
- 2 Repeat step 1 for each system installed, using the Amphenol cables on:
  - P2 for system 2
  - P3 for system 3
  - P4 for system 4

**Table 15.** *Subscriber Amphenol Connectors for Systems 1 through 4\**

Channel Unit	Circuit	Conn Pn† Tip	Conn Pn† Ring	Tip	Ring
1	1	26	1	WH/BL	BL/WH
	2	27	2	WH/OR	OR/WH
	3	28	3	WH/GN	GN/WH
	4	29	4	WH/BN	BN/WH
	5	30	5	WH/SL	SL/WH
	6	31	6	RD/BL	BL/RD
	7	32	7	RD/OR	OR/RD
	8	33	8	RD/GN	GN/RD
2	1	34	9	RD/BN	BN/RD
	2	35	10	RD/SL	SL/RD
	3	36	11	BK/BL	BL/BK
	4	37	12	BK/OR	OR/BK
	5	38	13	BK/GN	GN/BK
	6	39	14	BK/BN	BN/BK
	7	40	15	BK/SL	SL/BK
	8	41	16	YL/BL	BL/YL
3	1	42	17	YL/OR	OR/YL
	2	43	18	YL/GN	GN/YL
	3	44	19	YL/BN	BN/YL
	4	45	20	YL/SL	SL/YL
	5	46	21	VI/BL	BL/VI
	6	47	22	VI/OR	OR/VI
	7	48	23	VI/GN	GN/VI
	8	49	24	VI/BN	BN/VI
BYPASS		50	25	VI/SL	SL/VI

\* Shaded terminations are used only with 8 Channel POTS Units.

† Where *n* is 1 on System 1, 2 on System 2, 3 on System 3, and 4 on System 4.

## PGTC Connection

Connect the PGTC test interface cable to connector P26 (see [Figure 11](#)). Refer to [Table 16 on page 26](#) for PGTC connector pinouts.

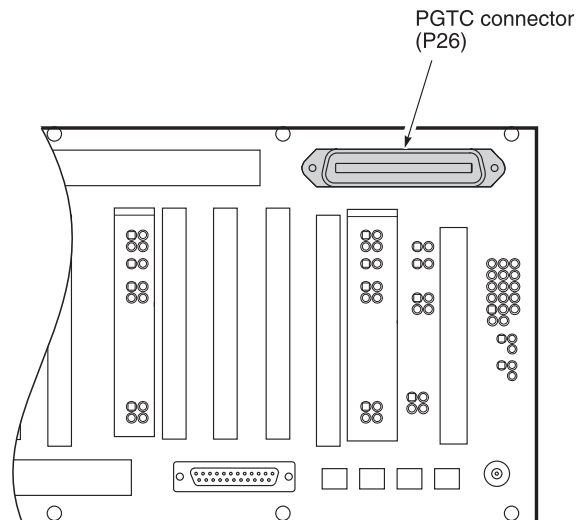

**Figure 11.** Connecting the PGTC Test Interface Cable

**Table 16.** PGTC Connector Pinouts

<b>Pin</b>	<b>Signal</b>	<b>Pin</b>	<b>Signal</b>
1	PGTC_RING1	26	PGTC_TIP1
2	PGTC_RING2	27	PGTC_TIP2
3	PGTC_RING3	28	PGTC_TIP3
4	PGTC_RING4	29	PGTC_TIP4
5	SLEEVE2	30	SLEEVE1
6	SLEEVE4	31	SLEEVE3
7	OH2	32	OH1
8	OH4	33	OH3
9	PROCEED2	34	PROCEED1
10	PROCEED4	35	PROCEED3
11	LOCK2	36	LOCK1
12	LOCK4	37	LOCK3
13	N/C	38	N/C
14	N/C	39	N/C
15	N/C	40	N/C
16	N/C	41	N/C
17	TMAJ	42	TSTALM
18	N/C	43	N/C
19	N/C	44	N/C
20	N/C	45	N/C
21	N/C	46	N/C
22	SEZBY	47	SEIZE
23	N/C	48	N/C
24	N/C	49	N/C
25	N/C	50	N/C

## FUSE

The FCS-719 COT shelf can be configured for a single battery feed or a split battery feed.

### Single Battery Feed Fuse

When the FCS-719 COT shelf is configured for a single battery feed, insert a 10 amp fuse into the equipment bay fuse panel where the PG-Flex CO battery wire is terminated.

### Split Battery Feed Fuse

When the FCS-719 COT shelf is configured for a split battery feed, insert a 5 amp fuse into the equipment bay fuse panel for each circuit (two circuits) where the PG-Flex CO battery wires are terminated.

## CABLING VERIFICATION



The following verifications should be done before any cards are inserted into the FCS-719 COT shelf.

- 1 Verify that there is a minimum of -42 Vdc and a maximum of -56 Vdc between the TB1 (-48V\_A) and TB4 (RTN\_A) screw terminals on the COT shelf.
- 2 Verify that there is a minimum of -42 Vdc and a maximum of -56 Vdc between the TB2 (-48V\_B) and TB3 (RTN\_B) screw terminals on the COT shelf.
- 3 Visually check that the HDSL lines are properly terminated and with the correct polarity.
- 4 Verify that the HDSL lines are “dry”:
  - There should be 0 Vdc between the Tip and Ring, Tip and Ground, and Ring and Ground for each of the HDSL circuits terminated on the shelf.
  - There should be > 100 kΩ resistance between the Tip and Ring, Tip and Ground, and Ring and Ground for each of the HDSL circuits terminated on the shelf.
- 5 Replace the clear Plexiglas™ cover.

## TURN-UP AND TESTING

Refer to the COT or RT Line Unit Technical Practices for complete COT and RT turn up and testing procedures.

## TROUBLESHOOTING

Refer to the COT or RT Line Unit Technical Practices for complete COT and RT troubleshooting procedures.

# PRODUCT SUPPORT

## TECHNICAL SUPPORT

Technical Assistance is available 24 hours a day, 7 days a week by the contacting Customer Service Engineering group at:

Telephone: 800.366.3891  
The 800 telephone support line is toll-free in the U.S. and Canada.

Email: [wsd\\_support@adc.com](mailto:wsd_support@adc.com)

Knowledge Base: [http://adc.com/Knowledge\\_Base/index.jsp](http://adc.com/Knowledge_Base/index.jsp)

Web: [www.adc.com](http://www.adc.com)

## LIMITED WARRANTY

Product warranty is determined by your service agreement. Refer to the ADC Warranty/Software Handbook for additional information, or contact your sales representative or Customer Service for details.

## RETURNS

To return equipment to ADC:

- 1 Locate the number of the purchase order under which the equipment was purchased. To obtain a return authorization number, you need to provide the original purchase order number to ADC's Return Material Authorization (RMA) Department.
- 2 Call or write ADC's RMA Department to ask for an RMA number and any additional instructions. Use the telephone number, fax number or email address listed below:
  - Telephone: 800.366.3891
  - Email Address: [rma@ADC.com](mailto:rma@ADC.com)
- 3 Include the following information, in writing, along with the equipment you are returning:
  - Company name and address.
  - Contact name and telephone number.
  - The shipping address to which ADC should return the repaired equipment.
  - The original purchase order number.
  - A description of the equipment that includes the model and part number of each unit being returned, as well as the number of units that you are returning.
  - The reason for the return. For example:
    - The equipment needs an ECO/ECN upgrade.
    - The equipment is defective.



**If the equipment is defective, please tell us what you observed just before the equipment malfunctioned. Be as detailed in your description as possible.**

If there is another reason for returning the equipment, please let us know so we can determine how best to help you.

- 4 Pack the equipment in a shipping carton.
- 5 Write ADC's address and the RMA Number you received from the RMA Department clearly on the outside of the carton and return to:

ADC DSL Systems, Inc.  
14352 Franklin Ave.  
Tustin, CA 92780-7013

Attention: **RMA (Number)**



**All shipments are to be returned prepaid. ADC will not accept any collect shipments.**

## **FCC CLASS A COMPLIANCE**

This equipment has been tested and found to comply with the limits for a Class A digital device, pursuant to Part 15 of the FCC rules. These limits are designed to provide reasonable protection against harmful interference when the equipment is operated in a commercial environment. This equipment generates, uses and can radiate radio frequency energy and, if not installed and used in accordance with the instruction manual, may cause harmful interference to radio communications. Operation of this equipment in a residential area is likely to cause harmful interference in which case the user will be required to correct the interference at his own expense.

## **Modifications**

The FCC requires the user to be notified that any changes or modifications made to this device that are not expressly approved by ADC voids the user's warranty.

All wiring external to the product(s) should follow the provisions of the current edition of the National Electrical Code.



---

# ACRONYMS

<b>ACO</b>	Alarm Cutoff
<b>AWG</b>	American Wire Gauge
<b>CO</b>	Central Office
<b>COT</b>	Central Office Terminal
<b>CU</b>	Channel Unit
<b>DLC</b>	Digital Loop Carrier
<b>HDSL</b>	High bit-rate Digital Subscriber Line
<b>ISDN</b>	Integrated Services Digital Network
<b>LAN</b>	Local Area Network
<b>MDF</b>	Main Distribution Frame
<b>NMA</b>	Network Management Analysis
<b>PGTC</b>	Pair Gain Test Controller
<b>POTS</b>	Plain Old Telephone Service
<b>RT</b>	Remote Terminal

---

**World Headquarters:**

ADC Telecommunications, Inc.  
12501 Whitewater Drive  
Minnetonka, Minnesota USA 55343

**For Technical Assistance:**

800.366.3891



1255343

---