



DSX-3 (DSX-4B-24) Front Cross-Connect Installation Instructions

| Content | Page |
|--|-----------|
| INTRODUCTION | 1 |
| Revision History | 1 |
| List of Changes | 2 |
| Related Publications | 2 |
| Admonishments | 2 |
| 1. DESCRIPTION | 2 |
| 2. INSTALLATION IN EQUIPMENT BAY | 4 |
| A. Chassis (DSX-4B-24) Installation | 4 |
| B. Cable Ring Installation | 6 |
| C. Circuit Module (DSX-4B-M) Installation | 6 |
| 3. POWER CONNECTIONS | 7 |
| 4. INSTALLATION OF CABLING | 7 |
| A. Office/Equipment Cable Routing | 7 |
| B. Office/Equipment Cable Termination | 10 |
| C. Cross-Connect Jumper Routing | 11 |
| D. Cross-Connect Jumpers | 13 |
| 5. SYSTEM CHECKOUT | 14 |
| 6. SYSTEMS INTEGRATION SERVICES | 14 |
| 7. CUSTOMER SUPPORT SERVICES | 15 |

INTRODUCTION

This manual provides instructions for adding to the modular DS3/DS4 Plug-In Digital Signal Front Cross-Connect (DSX-4B-24) System at the user's site. Read and understand the entire instruction sheet before beginning installation. For additional information on operation, refer to DSX-3 (DSX-4B-24) Front Cross-Connect System User Manual, ADCP-80-318.

Revision History

| ISSUE | DATE | REASON FOR CHANGE |
|---------|-------|---|
| Issue 1 | 12/89 | Original. |
| Issue 2 | 8/90 | Revised Paragraph 1.02 and 1.06. |
| Issue 3 | 4/91 | Technical changes. |
| Issue 4 | 11/92 | Change equipment and cross-connect cabling limitations. |
| Issue 5 | 5/97 | Update to current format standards. |

List of Changes

| PAGE | IDENTIFIER | DESCRIPTION OF CHANGE |
|-----------|------------|-----------------------|
| All Pages | – | Issue 5, May 1997 |

Related Publications

Listed below are related manuals and their publication numbers. For copies of these publications, contact ADC Technical Assistance Center at 1-800-366-3891 (in U.S.A. or Canada) or 612-946-3000, extension 3475 (outside U.S.A. and Canada).

| Title/Description | ADCP Number |
|--|-------------|
| Digital Signal Cross-Connect System (DSX-3) User Manual | ADCP-80-301 |
| Digital Signal Cross-Connect Applications Guide | ADCP-80-303 |
| DSX-3 (DSX-4B-24) Front Cross-Connect System User Manual | ADCP-80-318 |

Admonishments

Important safety admonishments are used throughout this manual to warn of possible hazards to persons or equipment. An admonishment identifies a possible hazard and then explains what may happen if the hazard is not avoided. The admonishments — in the form of Dangers, Warnings, and Cautions — must be followed at all times. These warnings are flagged by use of the triangular alert icon (seen below), and are listed in descending order of severity of injury or damage and likelihood of occurrence.



Danger: *Danger is used to indicate the presence of a hazard that **will** cause severe personal injury, death, or substantial property damage if the hazard is not avoided.*



Warning: *Warning is used to indicate the presence of a hazard that **can** cause severe personal injury, death, or substantial property damage if the hazard is not avoided.*



Caution: *Caution is used to indicate the presence of a hazard that **will** or **can** cause minor personal injury or property damage if the hazard is not avoided.*

1. DESCRIPTION

1.01 The DS3/DS4 Plug-In Digital Signal Front Cross-Connect (DSX-4B-24) System, shown in **Figure 1**, provides test access, patch, cross connect, and monitor functions in 75 ohm digital transmission systems operating with a common signal format and bit rate. For a complete description, refer to the user manual (ADCP-80-318).

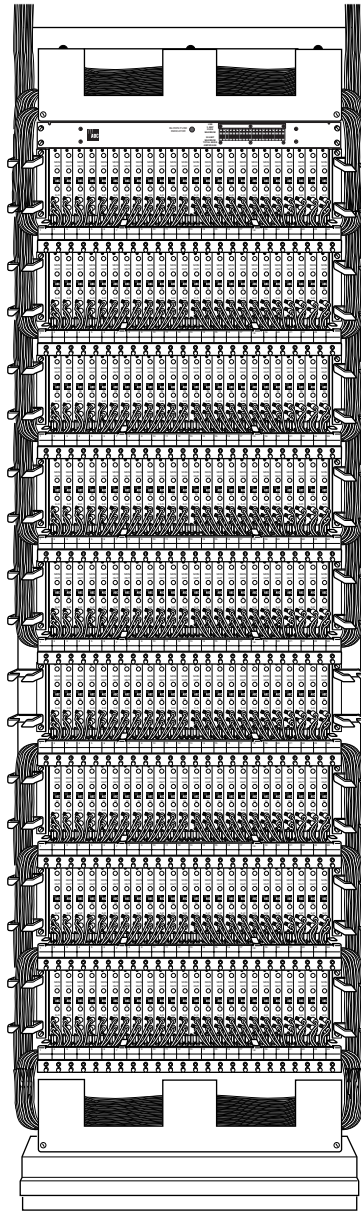

1689-A

**Figure 1. DSX-3 (DSX-4B-24) Front Cross-Connect System
(here with 734A Equipment IN/OUT and 735A Cross-Connect)**

Signal Levels

1.02 Each DSX-4B-24 bay serves as an equal level transmission point. All digital signals crossing a DSX-4B-24 bay must be maintained within a certain voltage power level for each specific bit rate. Reference ANSI T1.102-199x Draft, American National Standard for Telecommunications Digital Hierarchy Electrical Interfaces.

Cable Types

1.03 All DS3 and STS cables should be 75 ohm coaxial with tinned copper shield (735A Type and 734A Type or equivalent).

Cable Lengths

1.04 All digital equipment terminated at the DSX-4B-24 bay must have equalizers and/or pads which are adjusted for the particular cable lengths to maintain proper transmission levels. The maximum length between digital equipment and the DSX-4B-24 bay is governed by the specific equipment and cable type.

In/Out Equipment Cable

| EQUIPMENT TYPE | 734A OR EQUIVALENT CABLE | 735A OR EQUIVALENT CABLE |
|----------------|--------------------------|--------------------------|
| DS3 | 450 ft. (137.2 m) | 225 ft. (68.6 m) |
| DS4NA | 225 ft. (68.6 m) | 146 ft. (44.5 m) |
| STS-1 | 439 ft. (133.8 m) | 215 ft. (65.5 m) |
| STS-3 | 253 ft. (77.1 m) | 125 ft. (31.8 m) |

Cross-Connect Jumpers

| EQUIPMENT TYPE | RG59 CABLE | 735A OR EQUIVALENT CABLE | TRIAx CABLE |
|----------------|------------------|--------------------------|------------------|
| DS3 | 29.0 ft. (7.4 m) | 20.6 ft. (5.2 m) | 13.4 ft. (3.4 m) |
| DS4NA | 17.0 ft. (4.3 m) | 13.0 ft. (3.3 m) | 7.6 ft. (1.9 m) |
| STS-1 | 27.0 ft. (6.9 m) | 18.0 ft. (4.6 m) | 12.5 ft. (3.2 m) |
| STS-3 | 16.0 ft. (4.1 m) | 11.0 ft. (2.8 m) | 7.0 ft. (1.8 m) |

2. INSTALLATION IN NETWORK EQUIPMENT BAY



Warning: *Never install DSX equipment in a wet location or during a lightning storm. When installing or modifying telephone lines, disconnect lines at the network interface before working with uninsulated lines or terminals to prevent electrical shock.*

A. Chassis (DSX-4B-24) Installation

2.01 Existing bays should be expanded from the bottom up if office cables are brought into bay from above, or from the top down if office cables are brought into the bay from below.

2.02 Mounting brackets, cable rings, and hinged cable ring covers are shipped loose and must be attached with special thread forming screws (provided) to achieve proper grounding to the chassis. Screws must be tightened to 8-inch pounds minimum.

2.03 Identify hole locations for mounting chassis (module) in a typical 7-foot by 19- or 23-inch (2.13 m 48.26 or 58.42 cm) unequal flange equipment bay. See **Figure 2**.

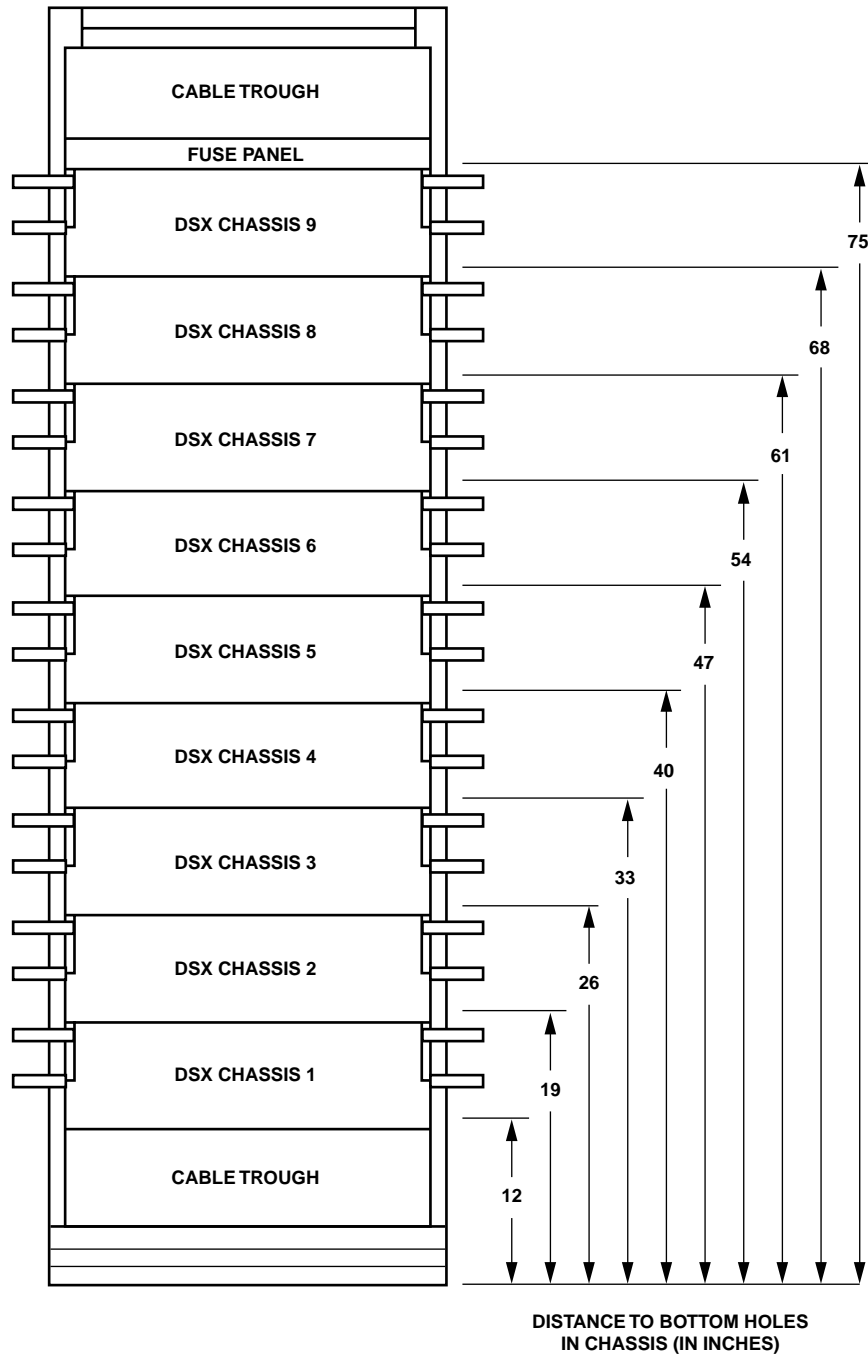

1690-A

Figure 2. Mounting Hole Locations

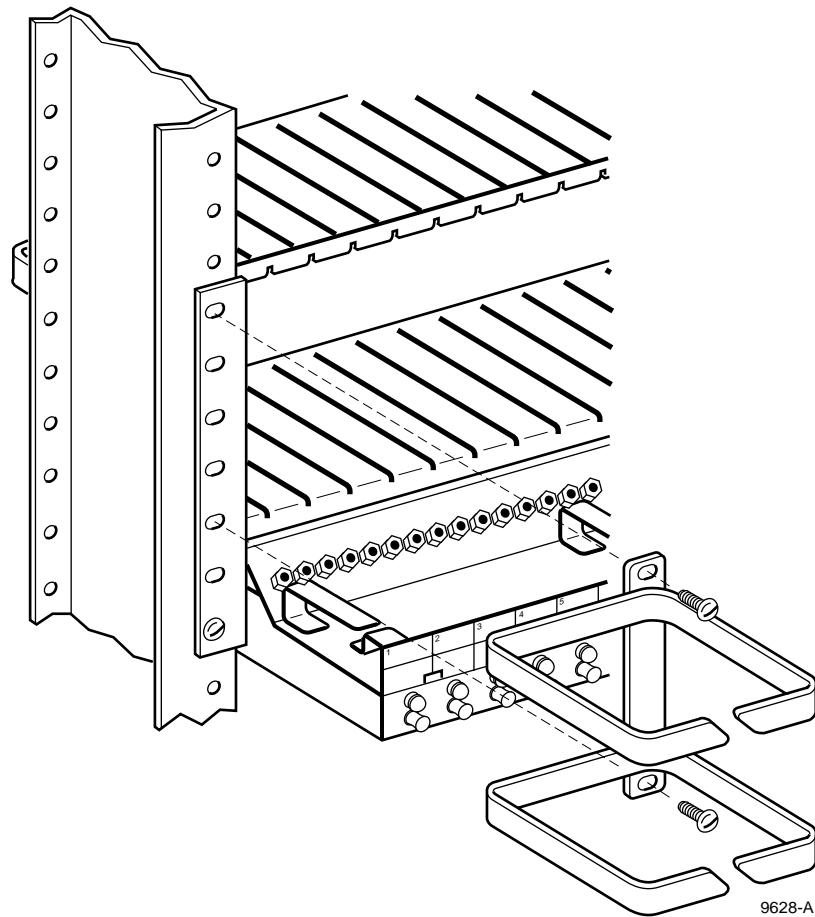

Figure 3. Chassis and Cable Ring Installation

2.04 Position chassis on bay in the appropriate location. Secure chassis to the bay using bottom holes on each side of the chassis, as shown in **Figure 3**.

B. Cable Ring Installation

2.05 Using the four #6-32 0.375 inch (.39 cm) screws provided, install the cable ring assembly on top of the chassis, as shown in **Figure 3**.

C. Circuit Module (DSX-4B-M) Installation

2.06 Install all DSX-4B-M circuit modules in the chassis. Press each module into the chassis. Secure each module with two #4-40 module retaining screws.

3. POWER CONNECTIONS

3.01 Remove fuse from fuse panel for the chassis being installed. When viewed from the front, fuses going from left to right correlate to chassis going from bottom to top. There is one fuse for each chassis.

3.02 Connect 22 AWG wires from the respective 48 V and GND terminals on the back of the chassis, as shown in **Figure 4**. Route and connect the 48 V to the NEG (-) wire wrap pin, and the GND to the POS (+) wire wrap pin, located on the rear surface of the fuse panel as shown in **Figure 5**.

3.03 Connect a 22 AWG wire from the chassis ground terminal to the bay ground wire or bay ground posts, whichever is provided.

3.04 Install a 0.5 Amp fuse in the fuse panel for the chassis being added.

4. INSTALLATION OF CABLING

A. Office/Equipment Cable Routing

4.01 Office/equipment cabling to the DSX-4B-24 is brought into the bay from either above or below and runs along the sides.

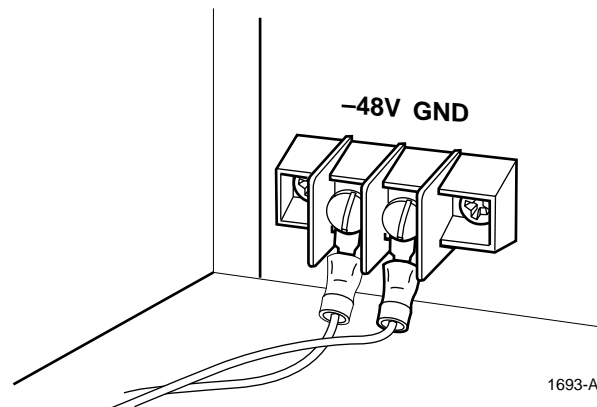

Figure 4. Power Connections

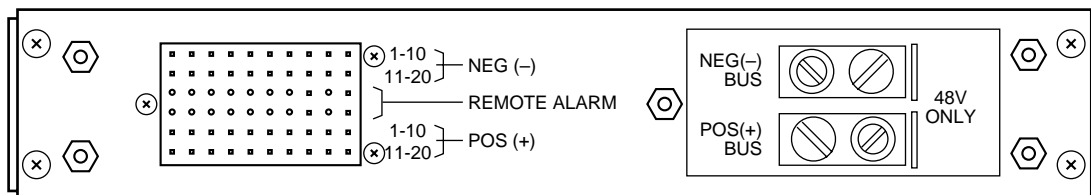

Figure 5. Fuse Panel

4.02 When viewed from the rear, make sure circuits 1 through 12 of each chassis run in the right side rack ducts and circuits 13-24 of each chassis run in the left side rack ducts.

Top Feed Cabling System

4.03 If cables are coming into the bay from above, cable attachment should start at the bottom and work up the bay. Using nylon tie-wraps or cable lacing, separate the cables into two bundles of 24 cables for each chassis. When viewed from the rear, the 24 cables from modules 13-24 should go to the left, with those from modules 1-12 going to the right, as shown in Figure 6.

4.04 Place cable bundles into rack ducts. Any cables not contained in the duct should be secured to the cable brackets on the rear of the bay.

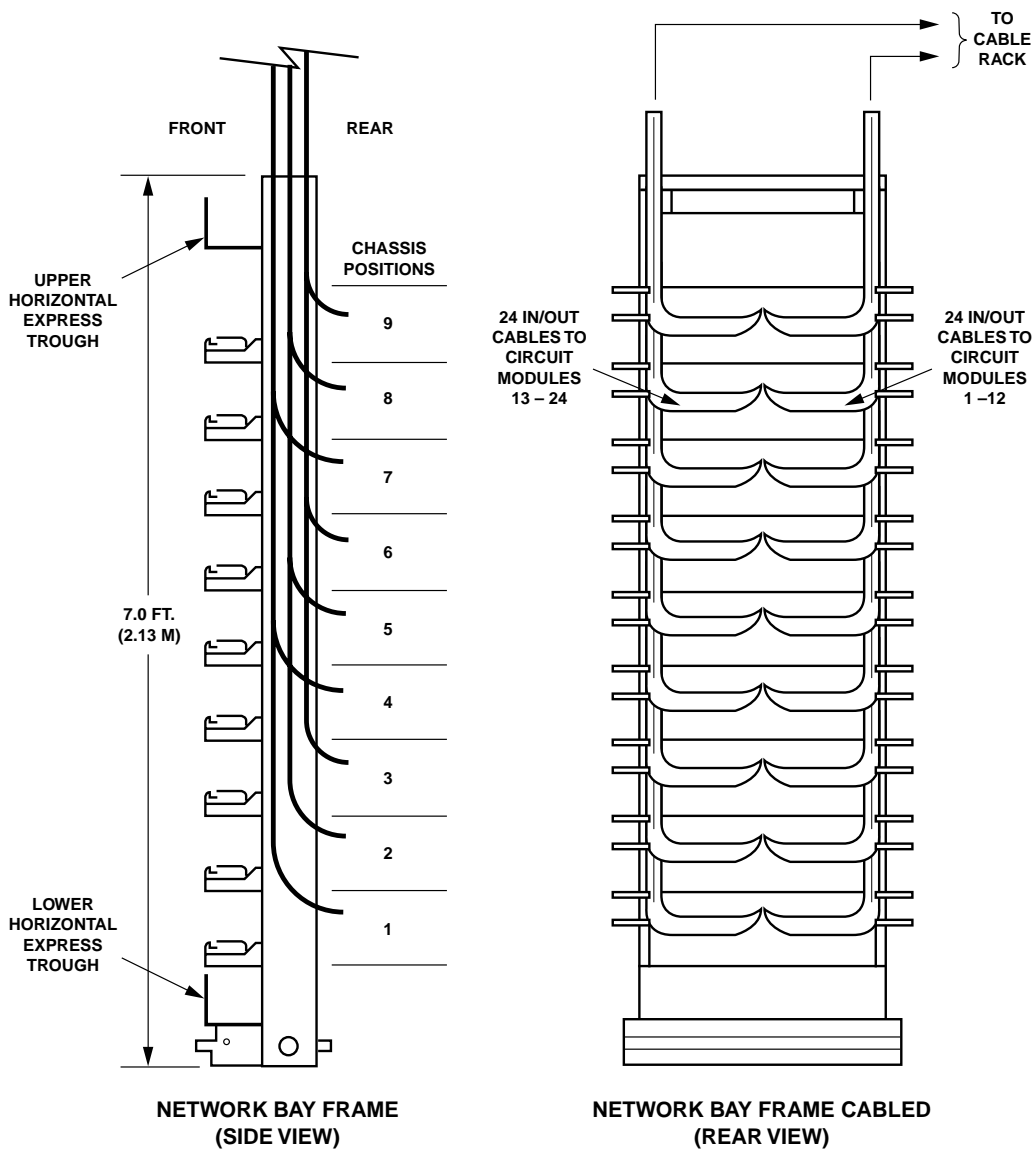

1694-A

Figure 6. Cable Routing for Top Feed Cabling System

Bottom Feeding Cabling System

4.05 If cables are coming into the bay from below, cable attachment should start at the top and work down the bay. Using nylon tie-wraps or cable lacing, separate cables into two bundles of 24 cables for each chassis. When viewed from the rear, the 24 cables from modules 13-24 should go to the left, with those from modules 1-12 going to the right, as shown in **Figure 7**. The floor clearance hole on each side of the frame should be 4 inches by 4 inches (10.2 cm by 10.2 cm), when using 734A or equivalent cable, or 2 inches by 4 inches (5 cm by 10.2 cm) if using 735A or equivalent cable.

4.06 Place cable bundles into rack ducts. Any cables not contained in the duct should be secured to the cable brackets on the rear of the bay.

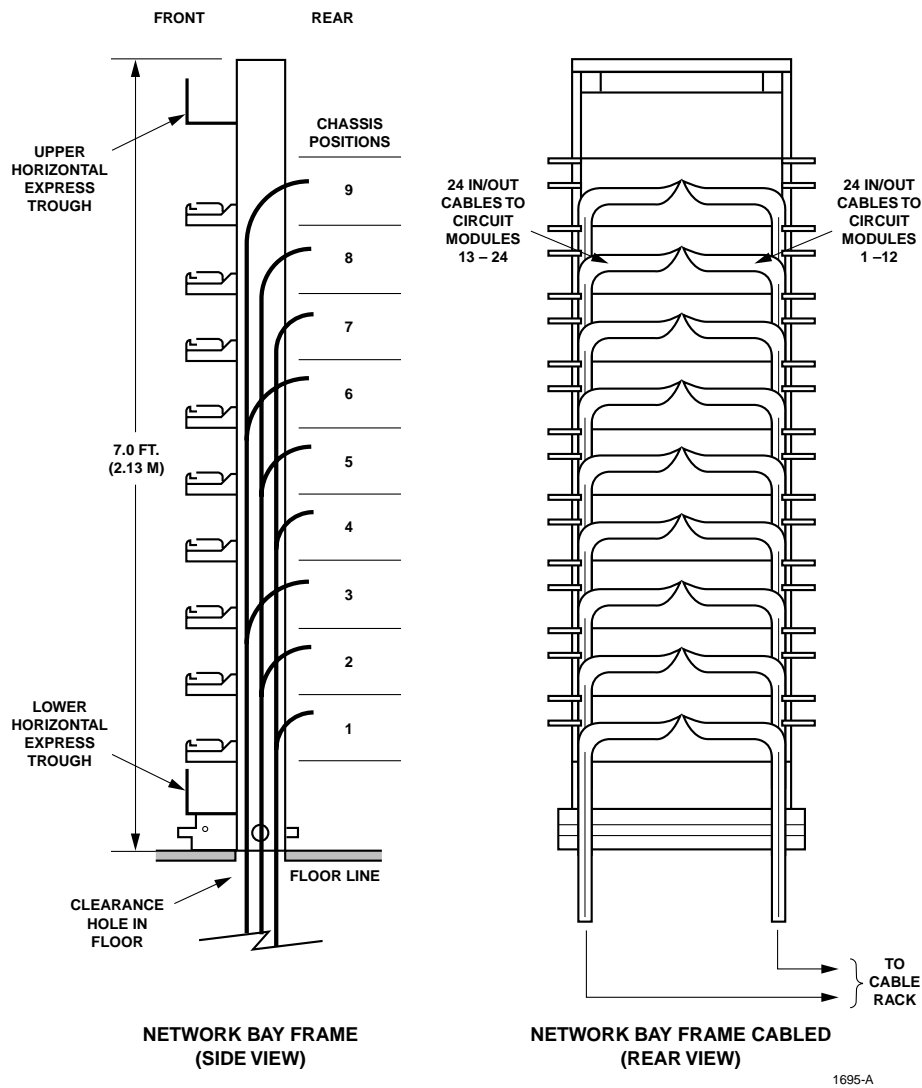

Figure 7. Cable Routing for Bottom Feed Cabling System

B. Office/Equipment Cable Termination

4.07 Office or equipment cables should be terminated to BNC or TNC connectors at the back of the DSX-4B-M circuit modules.

4.08 Install a BNC or TNC connector on each cable. Refer to the tables below for correct cable length and bend radius.

Cable Trim Length (Viewed from Rear)

| IN/OUT CONNECTOR TO RIGHT EDGE | | IN/OUT CONNECTOR TO LEFT EDGE | |
|--------------------------------|--------|-------------------------------|--------|
| MODULE | INCHES | MODULE | INCHES |
| 1 | 3.1 | 13 | 13.0 |
| 2 | 4.0 | 14 | 12.1 |
| 3 | 4.9 | 15 | 11.2 |
| 4 | 5.8 | 16 | 10.3 |
| 5 | 6.7 | 17 | 9.4 |
| 6 | 7.6 | 18 | 8.5 |
| 7 | 8.5 | 19 | 7.6 |
| 8 | 9.4 | 20 | 6.7 |
| 9 | 10.3 | 21 | 5.8 |
| 10 | 11.2 | 22 | 4.9 |
| 11 | 12.1 | 23 | 4.0 |
| 12 | 13.0 | 24 | 3.1 |

Cable Bend Radius

| CABLE TYPE | MINIMUM BEND RADIUS |
|--------------------|---------------------|
| 734A or Equivalent | 0.5 inches |
| 735A or Equivalent | 0.25 inches |

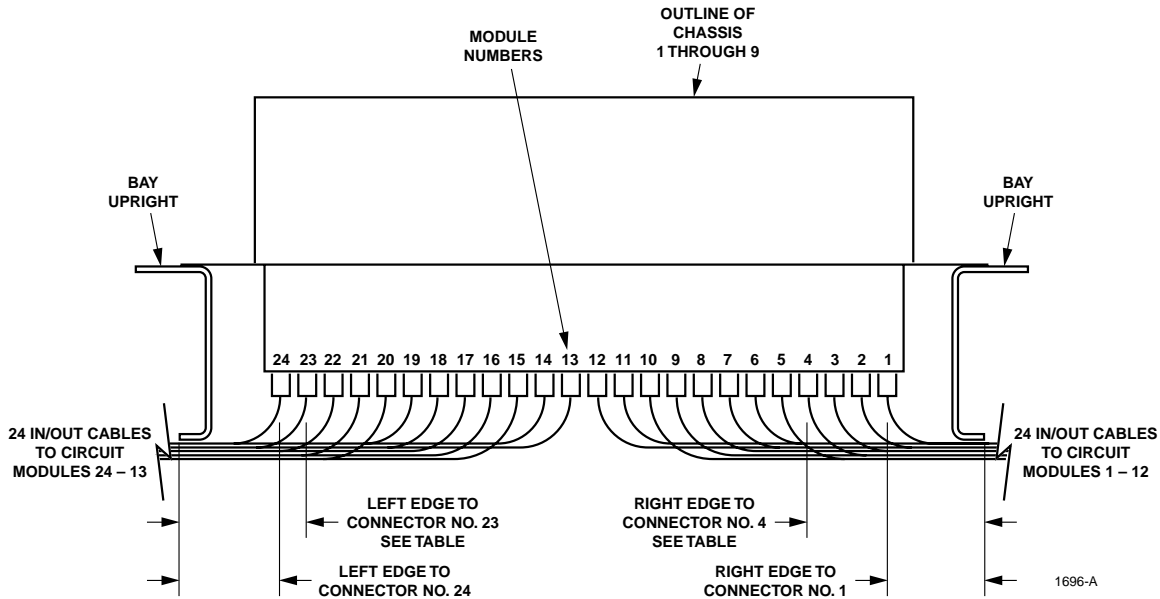

Figure 8. DSX-4B Cable Routing

4.09 Using tie-wraps, secure cables to the cable bar located on the back of each chassis. Record all terminations on an adhesive-backed designation label and apply label below the applicable circuit module.

C. Cross-Connect Jumper Routing

4.10 Cross-connect cables are installed at the front of the DSX-4B-M modules. Cross-connect jumpers should not exceed the lengths shown in paragraph 1.04 for each specific equipment type.

4.11 When installing cross-connect jumpers, cable congestion must be held to a minimum. This will simplify installation and provide optimal jumper traceability. This will also make DSX-4B-24 expansion and maintenance easier.

4.12 **Figure 9** illustrates rules for correct jumper routing. The same rules apply for any number of bays. To prevent unnecessary jumper buildup and congestion, remove all unused cross-connects from the wireways.

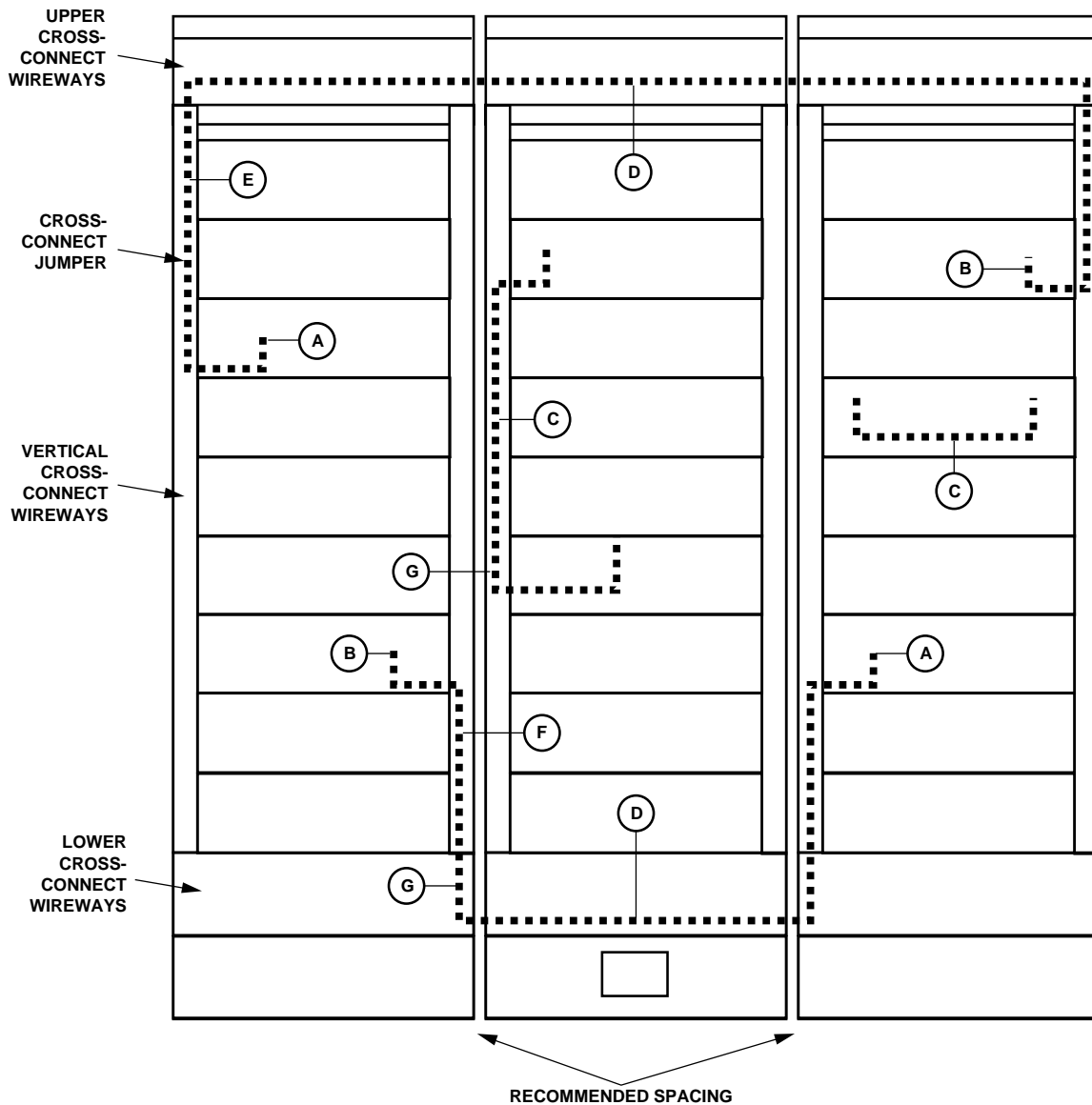

NOTE: BASED ON THE TYPE OF CABLE SELECTED FOR EQUIPMENT IN/OUT CABLING AND CROSS-CONNECT JUMPER, THE ADC RECOMMENDED SPACING IS AS FOLLOWS:

| APPLICATION | | SPACERS REQUIRED FOR UEF BAYS |
|---------------|--------------|---|
| EQUIPMENT I/O | X-CONN | |
| 735A/734A | 735A OR 0222 | ONE 10-INCH (25.4 CM) BETWEEN BAYS WITH ONE 5-INCH (12.7 CM) ON THE ENDS |

ROUTING RULES

- A. All jumpers in the left-hand side of the cross-connect field should enter and leave the bay from the left vertical wireways.
- B. All jumpers in the right-hand side of the cross-connect field should enter and leave the bay from the right vertical wireways.
- C. All intrabay cross-connects should use the vertical rings except when terminations are in the same panel.
- D. All interbay cross-connects should use the horizontal wireways.
- E. All jumpers originating in the upper half of the cross-connect field should route via the upper horizontal wireways.
- F. All jumpers originating in the lower half of the cross-connect field should route via the lower horizontal wireways.
- G. Whenever a jumper changes direction, it should do so at a ring or wireway.

1278-G

Figure 9. Recommended Cross-Connect Routing

D. Cross-Connect Jumpers

4.13 ADC DSX-4B-24 cross-connect jumpers are available in various lengths ranging from 1 to 27 feet (0.3 to 8.2 m). Cross-connect jumpers are also available with one connector attached and the other connector furnished unattached to be installed on site. These single-ended jumpers can be cut to the exact length required, which will reduce cross-connect congestion.

4.14 Using 735A type jumpers and accompanying messenger wires, cross-connect all necessary DSX-4B-24 circuits as shown in **Figure 10**.

1. Connect cross-connect OUT (X-O) of the first termination to the cross-connect IN (X-I) of the second termination. Connect the messenger wire pins of this cross-connect to either pin jack (XO or XI) on each termination.
2. Connect cross-connect IN (X-I) of the first termination to the cross-connect OUT (X-O) of the second termination. Connect the messenger wire pins of this cross-connect to the remaining pin jack on each termination.

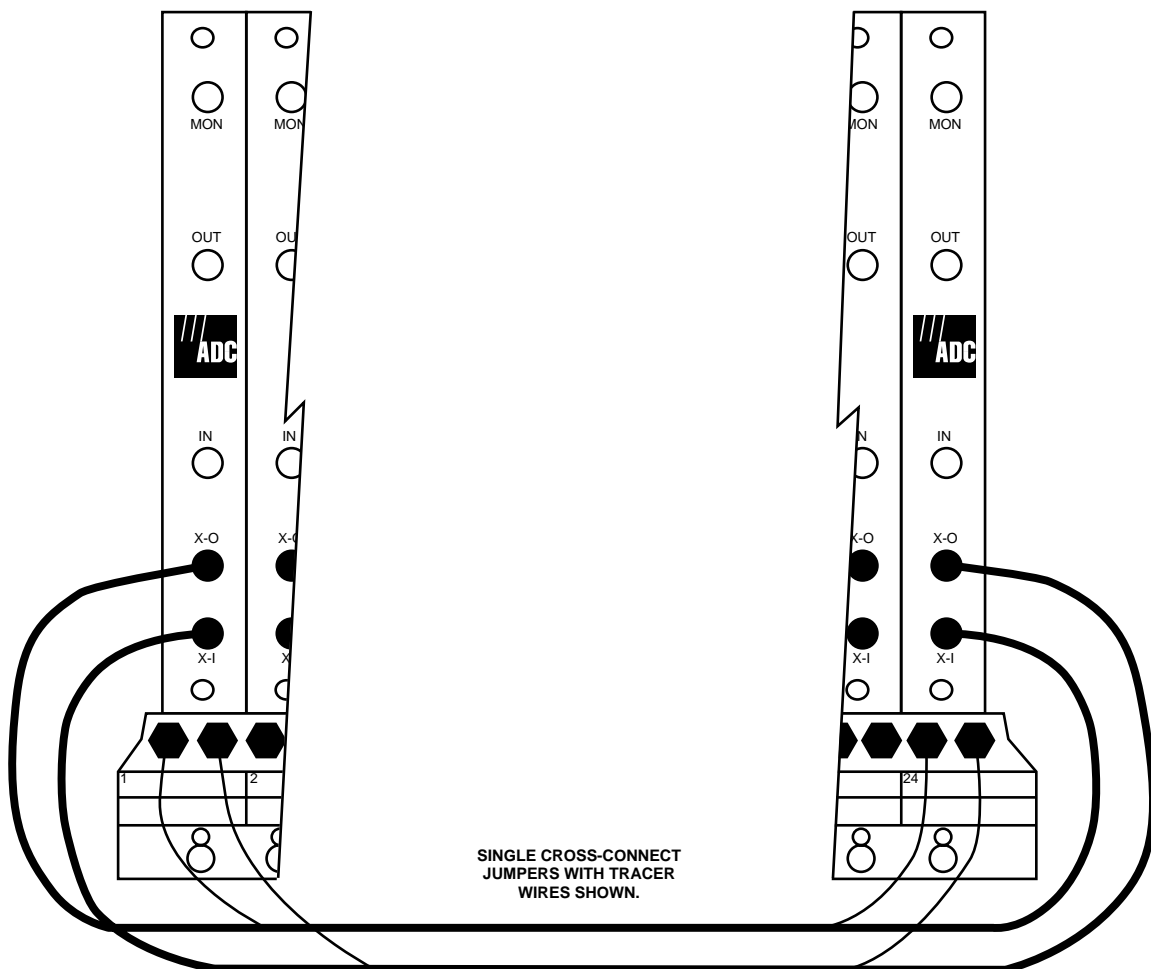

Figure 10. DSX-4B-24 Cross Connections

5. SYSTEM CHECKOUT

5.01 Place a 0.5 Amp fuse in the fuse panel for each DSX-4B-24 chassis added to each bay. When viewed from the front, fuses going from left to right correlate to chassis going from bottom to top. There is one fuse for each chassis.

5.02 Cross-connect wiring can be checked as necessary by pulling the tracer lamp button below any DSX-4B-M circuit module. Pulling this button will cause the corresponding tracer lamp and the tracer lamp at the other end of the cross-connect to flash for approximately 30 seconds and then remain lit until the button is pushed back in.

6. SYSTEM INTEGRATION SERVICES

6.01 ADC offers the following system integration services. For calls originating in the U.S.A. or Canada, dial **1-800-366-3891, extension 3000**. For calls originating outside the U.S.A. or Canada, dial **612-946-3000**.

| | |
|------------------------------------|--|
| Technical Assistance Center | <ul style="list-style-type: none">• Product Management• Project Engineering• Project Administration• Network Design• Broadband Design (RF Design and Strand Mapping)• Integration Network Testing• Network Monitoring (Upstream or Downstream)• Power Monitoring• Remote Surveillance• System Turn-Up and Test• Service/Maintenance Agreements |
| Technical Training | <ul style="list-style-type: none">• Product Technology• Custom Designed Training |
| Technical Operations | <ul style="list-style-type: none">• Detail Engineering• End-to-End Installation• Drafting Services |

7. CUSTOMER SUPPORT SERVICES

7.01 ADC offers the following customer support services. For calls originating in the U.S.A. or Canada, dial **1-800-366-3891**, then request the extension listed. For calls originating outside the U.S.A. or Canada, dial **612-946-3475** or **612-946-3000**.

| | |
|---|---|
| BCG Technical Assistance Center Extension 3475 E-Mail: bcgtac@adc.com | <ul style="list-style-type: none">• Technical Information• System/Network Configuration• Product Specification• Product Application• Training• Installation and Operation Assistance• Troubleshooting and Repair• Field Assistance |
| Sales Administration Extension 3000 | <ul style="list-style-type: none">• Quotation Proposals• Ordering• Delivery• General Product Information |
| Product Return Department Extension 3000 E-Mail: repair&return@adc.com | <ul style="list-style-type: none">• ADC Return Authorization number and instructions must be obtained before returning products. |

7.02 Product information and service can also be obtained by writing ADC Telecommunications, Inc., 4900 West 78th Street, Minneapolis, Minnesota 55435, U.S.A.

Contents herein are current as of the date of publication. ADC reserves the right to change the contents without prior notice. **In no event shall ADC be liable for any damages resulting from loss of data, loss of use, or loss of profits and ADC further disclaims any and all liability for indirect, incidental, special, consequential or other similar damages. This disclaimer of liability applies to all products, publications and services during and after the warranty period.**

This publication may be verified at any time by contacting ADC's Technical Assistance Center at 1-800-366-3891, extension 3475 (in U.S.A. or Canada) or 612-946-3475 (outside U.S.A. and Canada), or by writing to ADC Telecommunications, Inc., Attn: Technical Assistance Center, Mail Station #77, 4900 West 78th Street, Minneapolis, MN 55435, U.S.A.

