

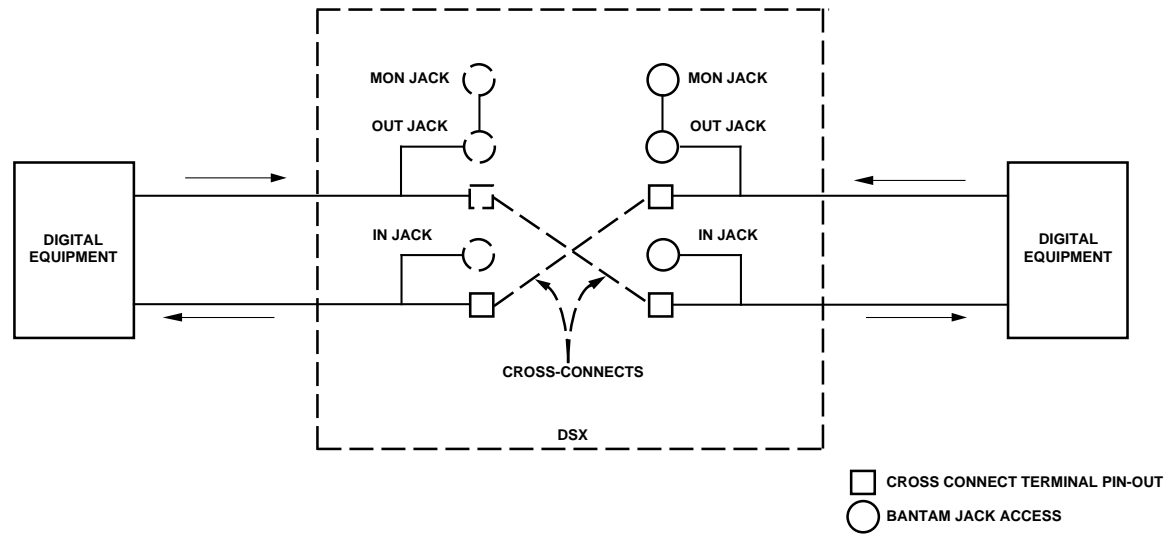

## DSX-1 TROUBLE ISOLATION PROCEDURE

Contents	Page
<b>DSX TRANSMISSION SIGNAL DIRECTION</b> .....	<b>2</b>
<b>PROCEDURE 1—TROUBLE ISOLATION WITHOUT TEST EQUIPMENT</b> .....	<b>3</b>
<b>PROCEDURE 2—TROUBLE ISOLATION USING TEST EQUIPMENT</b> .....	<b>5</b>
<b>PROCEDURE 3—DSX JACK CONTINUITY TESTS (JACK CONTACTS OPERATED)</b> .....	<b>11</b>
<b>PROCEDURE 4—DSX JACK CONTINUITY TESTS (JACK CONTACTS NORMAL)</b> .....	<b>13</b>



**DSX Transmission Signal Flow**

**CABLING LENGTHS AND SIGNAL LEVEL FOR GIVEN SIGNAL TYPE**

SIGNAL TYPE	SIGNAL LEVEL	IN/OUT CABLE— GAUGE/MAX LENGTH	CROSS-CONNECT CABLE— GAUGE/MAX LENGTH
DS-1	+ 2.4—3.6 Volts (+3.0 Volts nominal)	22 AWG/655 feet (200 m) 26 AWG/450 feet (137 m)	24 AWG/85 feet (25.9 m)
DS-1C	+ 2.3—4.2 Volts (+3.0 Volts nominal)		
DS-2	+ .055—1.3 Volts (+3.0 Volts nominal)	22 AWG/1050 feet (320 m)	26 AWG/15 feet (4.6 m)

## PROCEDURE 1—TROUBLE ISOLATION WITHOUT TEST EQUIPMENT

This procedure loops equipment at the DSX jack to isolate trouble.

► **Note:** This procedure is based on complete failure of an In Service circuit, some actions are of an intrusive nature.

STEP	PROCEDURE
1	Identify near end/far end DSX circuit cross-connects by inserting a patch plug into the near end MON jack. Observe the tracer lamp LEDs. Both LEDs will flash for approximately 30 seconds, and then remain lit. See <a href="#">Figure 1</a> .
2	Loop the <b>near end equipment</b> by inserting a patch cord or looping plug into the OUT and IN jacks of the affected DSX Circuit. Refer to <a href="#">Figure 1</a> .
2a	Did near end equipment restore? YES—network facility and network elements are in working order. Trouble is most likely associated with far end. Go to Step 3. NO—Either the near end network facility or network element is defective. Follow manufacturers trouble analysis procedures for network element equipment diagnostics and further identification of trouble source. If network equipment tests OK, proceed to <a href="#">Procedure 2—Trouble Isolation With Test Equipment</a> .
3	Loop the <b>far end equipment</b> by inserting a patch cord or looping plug into the OUT and IN jacks of the affected DSX Circuit. Refer to <a href="#">Figure 1</a> .
3a	Did far end equipment restore? YES—network facility and network elements are in working order. Trouble is most likely associated with cross-connect jumpers. Go to Step 4. NO—Either the far end network facility or network element is defective. Follow manufacturers trouble analysis procedures for network element equipment diagnostics and further identification of trouble source. If network equipment tests OK, proceed to <a href="#">Procedure 2—Trouble Isolation With Test Equipment</a> .
4	Visually inspect <b>cross-connect jumper</b> wiring. See <a href="#">Figure 2</a> . Inspect for broken wires, wiring clippings or shorted wire wrap pins. Verify that the OUT T&R connections of near end network element are cross-connected to the IN T1&R1 connections of the far end network element. Verify that the IN T1&R1 connections of the near end network element are cross-connected to the OUT T&R connections of the far end network element.
5	If the above Steps 1 through 4 fail to resolve the problem, proceed to <a href="#">Procedure 2—Network Failure Trouble Isolation With Test Equipment</a> .

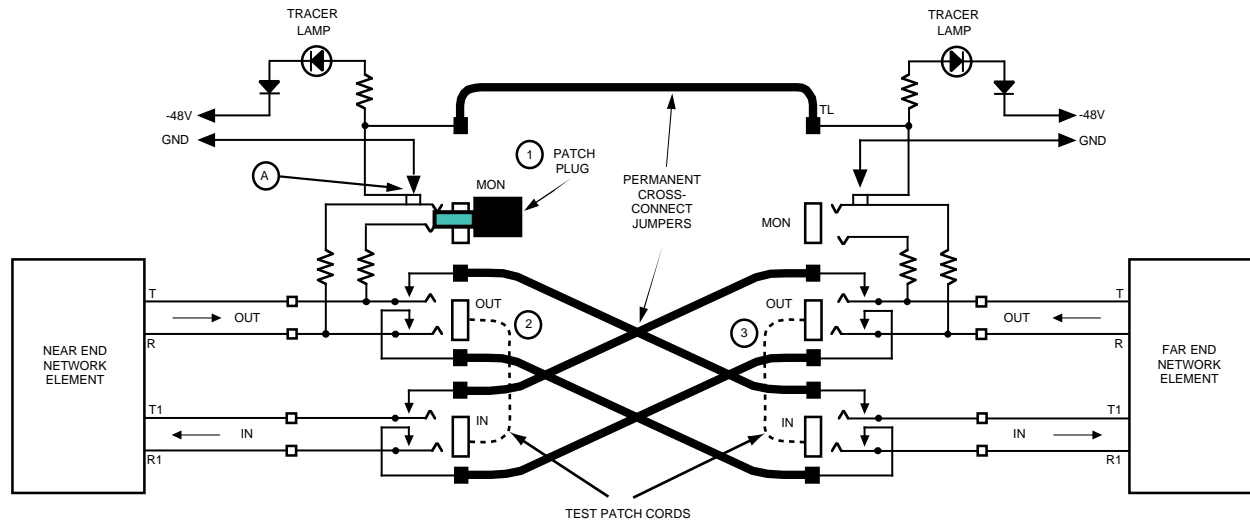

Note: A plug inserted in the MON jack causes contacts to make at A extending ground to both LED tracer lamps which will flash for approximately 30 seconds, and then remain lit. There is no service interruption.

8602-A

Figure 1. Trouble Isolation without Test Equipment

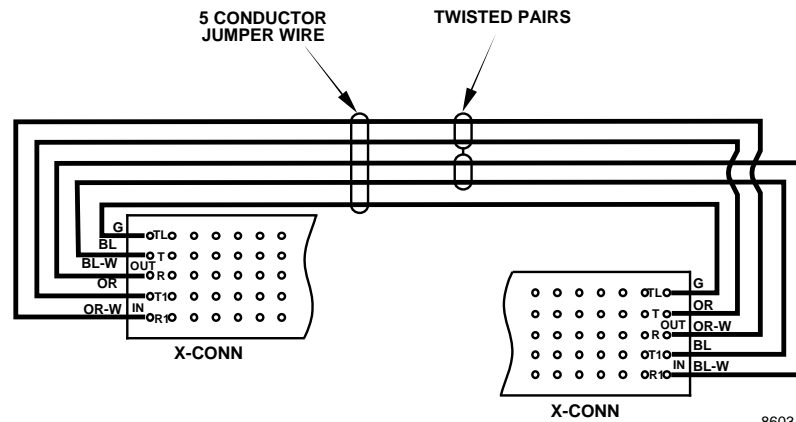

8603-A

Figure 2. Cross-Connect Terminal Blocks

## PROCEDURE 2—TROUBLE ISOLATION USING TEST EQUIPMENT

This procedure will isolate equipment trouble conditions using DSX-1 Signaling Test Equipment.

► **Note:** This procedure is based on complete failure of an In-Service circuit, some actions are of an intrusive nature.

STEP	PROCEDURE
1	<p>Verify <b>proper operation of test equipment and test patch cords</b> prior to performing trouble shooting procedures. See <b>Figure 3</b> for step 1, 2 and 3 test set connections.</p> <p>Loop the T-1 test equipment by inserting a test patch cord into the TRANSMIT and RECEIVE jacks of the test unit. Verify that the T-1 test set is transmitting and receiving a proper signal without errors.</p>
2	<p>Identify the near end/far end <b>DSX circuit cross-connects</b> by inserting a patch plug into the near end DSX MON jack. Observe tracer lamp LEDs. Both LEDs will flash for approximately 30 seconds, and then remain lit.</p>
	<p><b>NEAR END TEST</b></p>
3	<p>Set the test equipment receiver to the MON TERMINATION mode.</p> <p>Insert the patch cord from the test equipment RECEIVE jack into the near end DSX MON jack. Verify near end equipment OUT signal.</p>
3a	<p>Is an error free signal received?</p> <p>YES—the near end network element and network facility is transmitting the proper signal. Proceed to Step 4.</p> <p>NO, The possible troubles are either in the cabling, in near end equipment or in the DSX jack.</p>
	<p><b>Testing for reversed cabling (reversed cable)</b></p>
3b	<p>Set the test equipment receive function to TERM mode and insert the patch cord into the near end DSX IN jack.</p> <p>Is an error free signal received?</p> <p>YES—the near end network element IN and OUT cabling is reversed. The network element is transmitting the digital signal to the DSX IN jack, it must be cabled to transmit the signal to the OUT jack. Perform visual inspection of cabling and terminations to determine where cabling reversal has occurred. Correct cabling reversal.</p> <p>NO—the trouble is most likely associated with either a near end element transmit signal or network facility failure. Follow manufacturers trouble analysis procedure for appropriate network equipment diagnostics and identification of trouble source. If manufacturers network equipment tests OK, proceed to Step 6.</p>

(continued)

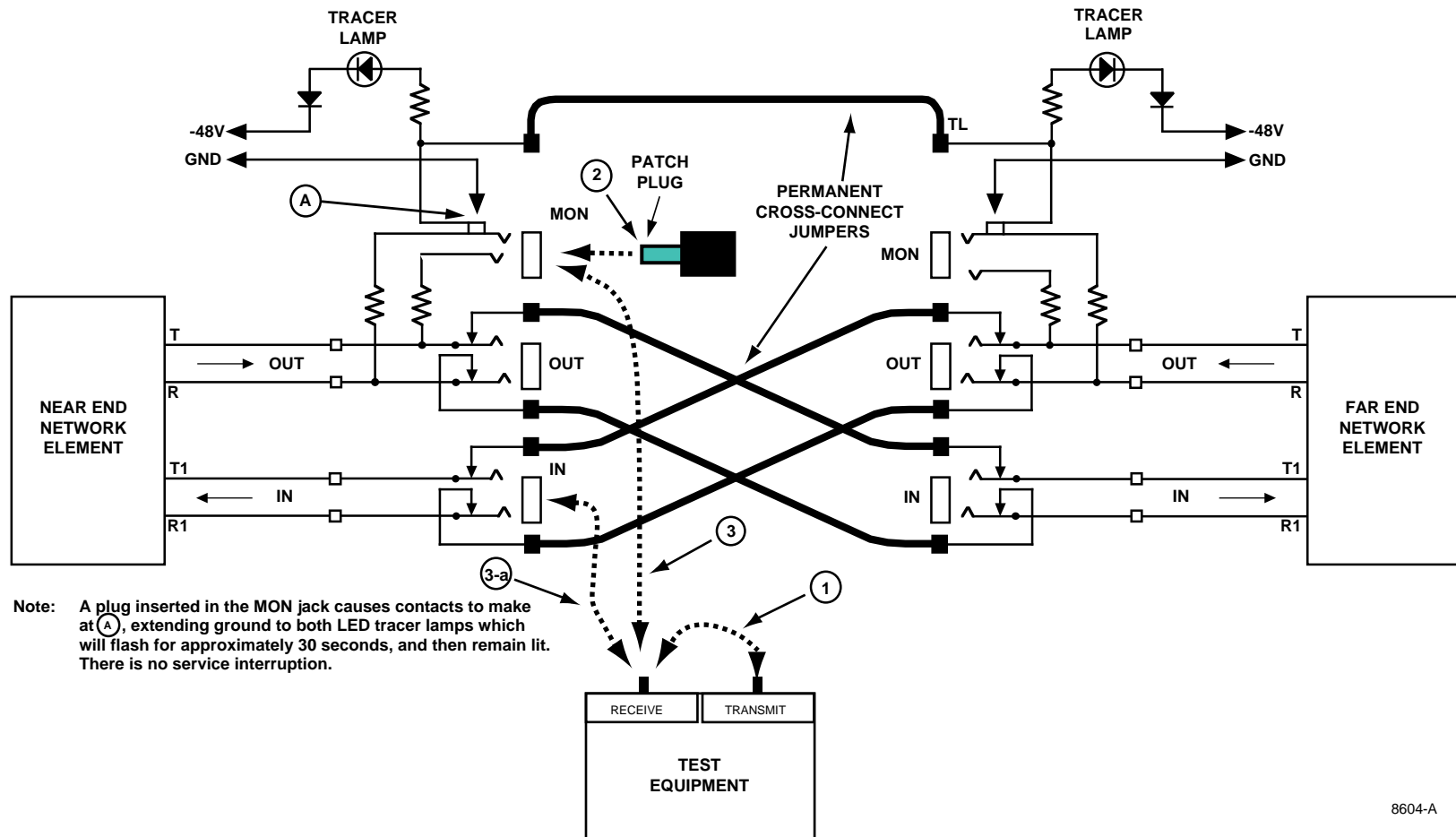

8604-A

Figure 3. Test Set Setup and Signal Test Access

**PROCEDURE 2—TROUBLE ISOLATION USING TEST EQUIPMENT, continued**

STEP	PROCEDURE
<p>4</p> <p>4a</p> <p>4b</p>	<p><b>FAR END TEST</b></p> <p>Set the test equipment receiver function to MON Termination mode. Insert the RECEIVE test equipment patch cord into the far end DSX MON jack. Verify far end equipment OUT signal. See <b>Figure 4</b>.</p> <p>Is an error free signal received?</p> <p>YES—the far end network facility and network element are transmitting proper signal. Proceed to Step 5.</p> <p>NO, the possible troubles are either in the cabling, far end equipment or in DSX jack.</p> <p><b>Testing for reversed cabling</b></p> <p>Set the test equipment receive function to TERM mode and insert patch cord into the far end DSX IN jack.</p> <p>Is an error free signal received?</p> <p>YES—the far end network element IN and OUT cabling is reversed. The network element is transmitting the digital signal to the DSX IN jack, it must be cabled to transmit the signal to the OUT jack. Perform visual inspection of cabling and terminations to determine where cabling reversal has occurred. Correct cabling reversal.</p> <p>NO—the trouble is most likely associated with either a far end element transmit signal or network facility failure. Follow manufacturers trouble analysis procedure for appropriate network equipment diagnostics and identification of trouble source. If manufacturers network equipment tests OK, proceed to Step 6.</p>
<p>5</p>	<p>Visually inspect the cross-connect jumper wiring for broken wires, wire clippings, or shorted wire wrap pins at the cross-connect terminal block. See <b>Figure 5</b>.</p> <p>Verify that T&amp;R OUT connections of near end network element are cross-connected to T1&amp;R1 IN connections of the far end network element.</p> <p>Verify that the T&amp;R OUT connections of the far end element are cross-connected to the T1&amp;R1 IN connections of the near end network element.</p>

(continued)

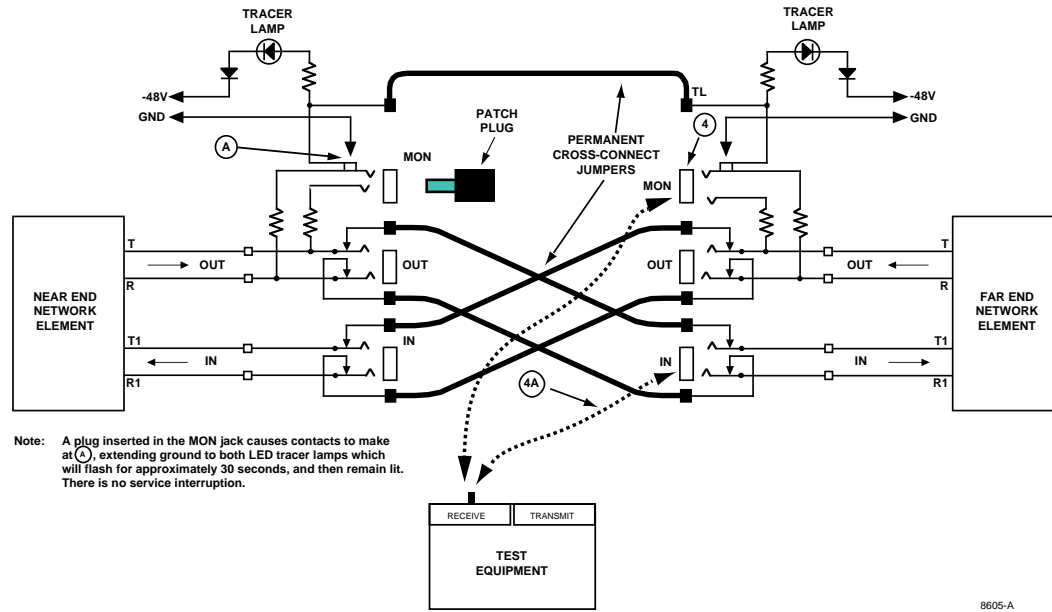

8605-A

Figure 4. Far End Tests

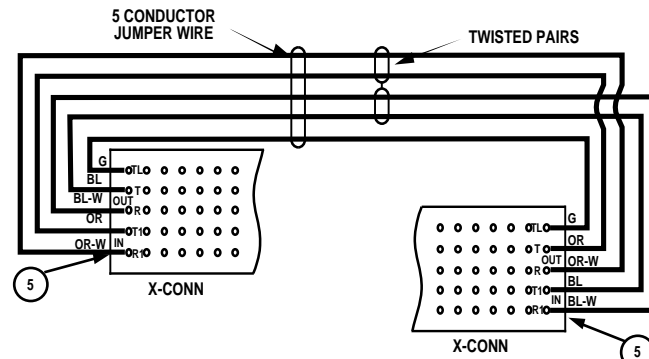

8606-A

Figure 5. Cross-Connect Wiring at Terminal Block



**PROCEDURE 2—TROUBLE ISOLATION USING TEST EQUIPMENT, continued**

STEP	PROCEDURE
6	<p><b>DSX MODULE VS CABLE/EQUIPMENT ISOLATION TEST</b></p> <p>Unwrap the appropriate (near end or far end) DSX IN and OUT cable pair wires that are terminated on the DSX termination block field. See <a href="#">Figure 6</a>.</p> <p>Connect the network element OUT cable pair to the receive section of the transmission test set. (Receive section of transmission test set to TERM mode.)</p> <p>Connect the network element IN cable pair to the transmit section of the transmission test set. (Transmit set to send 0dB DS-1 signal.)</p> <p><b>Perform DS-1 transmission tests.</b></p>
6a	<p>Is an error free signal received? (Receive section test)</p> <p>YES—trouble is associated with the DSX jack. <a href="#">Proceed to Procedure 3</a>—DSX Jack Continuity Tests (Jack Contacts Operated)</p> <p>NO—trouble is associated with either the network element, network facility, or intraoffice cabling. Repeat tests starting from Procedure 2. Trouble must be resolved before service can be restored.</p>
6b	<p>Network element restored to service from test set generated signals? (Transmit test)</p> <p>YES—trouble is associated with the DSX jack. <a href="#">Proceed to Procedure 3</a>—DSX Jack Continuity Tests (Jack Contacts Operated).</p> <p>NO—trouble is associated with either the network element, network facility, or intraoffice cabling. Repeat tests starting from Procedure 2. Trouble must be resolved before service can be restored.</p>

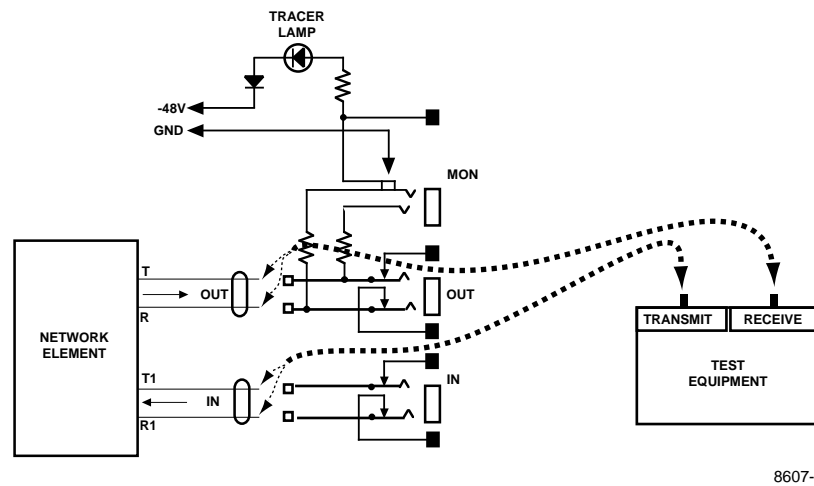

8607-A

Figure 6. IN/OUT Termination Block

### PROCEDURE 3—DSX JACK CONTINUITY TESTS (JACK CONTACTS OPERATED)

This procedure tests the DSX jack wiring and jack contacts with the jack contacts in an operated position.

STEP	PROCEDURE
1	Remove all wiring connections at the suspect DSX jack. Obtain three test cords equipped with alligator clips on one end and jack plug on the other end. Insert the test cords into the MON, OUT and IN jacks.
2	Set up each test as shown in <b>Table 1</b> . See <b>Figure 7</b> . Perform continuity tests with the jack contacts operated.
3	Observe meter readings and verify test requirements for each wire path as shown in <b>Chart 1</b> .
4	Did all continuity tests pass? Yes, <b>Proceed to Procedure 4</b> . No, the jack is defective. Reassign to another DSX jack. Contact ADC field support at 800-366-3891 Ext. 3475 for assistance to repair the defective jack.

**Table 1. DSX Jack Continuity Test 1 Setup**

MONITOR jack TIP test	Clip the test cord TIP conductor onto test meter NEG. probe. Place test meter POS. probe on test points shown on test chart (see <b>Figure 7</b> and <b>Chart 1</b> ). Observe test meter reading and verify proper condition as shown on Chart 1.
MONITOR jack RING test	Clip the test cord RING conductor onto test meter NEG. probe. Place test meter POS. probe on test points shown on test chart (see <b>Figure 7</b> and <b>Chart 1</b> ). Observe test meter reading and verify proper condition as shown on Chart 1.
OUT jack TIP test	Clip the test cord TIP conductor onto test meter NEG. probe. Place test meter POS. probe on test points shown on test chart (see <b>Figure 7</b> and <b>Chart 1</b> ). Observe test meter reading and verify proper condition as shown on Chart 1.
OUT jack RING test	Clip the test cord RING conductor onto test meter NEG. probe. Place test meter POS. probe on test points shown on test chart (see <b>Figure 7</b> and <b>Chart 1</b> ). Observe test meter reading and verify proper condition as shown on Chart 1.
IN jack TIP test	Clip the test cord TIP conductor onto test meter NEG. probe. Place test meter POS. probe on test points shown on test chart (see <b>Figure 7</b> and <b>Chart 1</b> ). Observe test meter reading and verify proper condition as shown on Chart 1.
IN jack RING test	Insert test cord into IN jack. Clip the test cord RING conductor onto test meter NEG. probe. Place test meter POS. probe on test points shown on test chart (see <b>Figure 7</b> and <b>Chart 1</b> ). Observe test meter reading and verify proper condition as shown on Chart 1.

**Chart 1. DSX Jack Assembly Wiring Continuity Test Requirements (Jacks Operated)**

JACK CONTACTS OPERATED (TEST CORDS* INSERTED IN MON, OUT AND IN JACKS)		CROSS-CONNECT TERMINAL BLOCK TERMINAL WIREWRAP PIN				IN/OUT TERMINAL BLOCK WIREWRAP PIN				DSX CHASSIS GROUND
		OUT		IN		OUT		IN		
		TN	RN	TN	RN	T	R	T	R	
MON JACK	T#	N	N	N	N	Y	N	N	N	N
	R#	N	N	N	N	N	Y	N	N	N
OUT JACK	T#	N	N	N	N	Y	N	N	N	N
	R#	N	N	N	N	N	Y	N	N	N
IN JACK	T#	N	N	N	N	N	N	Y	N	N
	R#	N	N	N	N	N	N	N	Y	N

**Notes:** #- Negative Reference Lead (Test Set Neg. Probe). Y = Continuity. N = No Continuity (open). \*Use test cords equipped with alligator clips or equivalent.

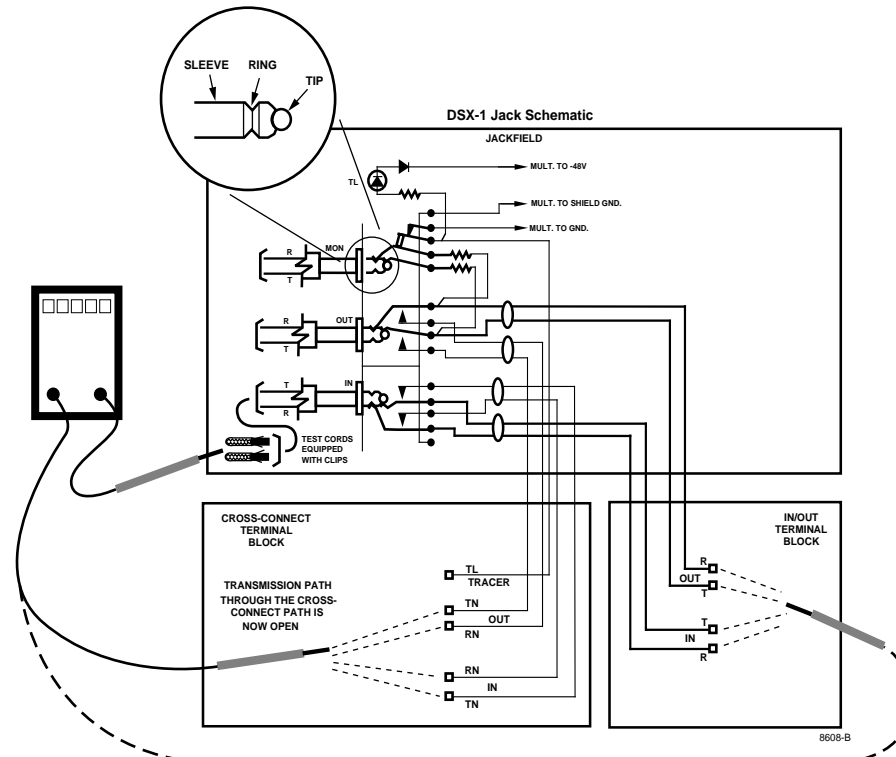

**Figure 7. Continuity Test Set Connections (Jacks Operated)**

### PROCEDURE 4—DSX JACK CONTINUITY TESTS (JACK CONTACTS NORMAL)

This procedure tests the DSX jack wiring and jack contacts with the jack contacts in the normal position.

STEP	PROCEDURE
1	If not already done, remove all wiring connections at the suspect DSX jack. Ensure there are no cords or plugs in the MON, OUT or IN jacks.
2	Set up each test as shown in <a href="#">Table 2</a> . See <a href="#">Figure 8</a> . Perform continuity tests with the jack contacts normal.
3	Observe meter readings and verify test requirements for each wire path as shown in <a href="#">Chart 2</a> .
3b	<p>Did all continuity tests pass?</p> <p>YES—To insure all prior tests were successfully completed, repeat tests starting from Procedure 2. If trouble is not found and continuity tests pass again, the trouble is not associated with the DSX jack. If unable to resolve the trouble condition and assistance is required, contact ADC field support at 800-366-3891 Ext. 3475.</p> <p>NO—the jack is defective. Reassign circuit to another DSX jack. Contact ADC field support at 800-366-3891 Ext. 3475 for assistance to repair the defective jack.</p>

**Table 2. DSX Jack Continuity Test 2 Setup**

OUT TN to each cross-connect and IN/OUT terminal block wire wrap pin	Place the test meter NEG probe on the OUT TN terminal. Touch the POS probe to the cross-connect terminal block OUT RN, IN TN, IN RN, and then the IN/OUT terminal block OUT T, OUT R, IN T and IN R. Observe test meter reading and verify proper condition as shown on <a href="#">Chart 2</a> .
OUT RN to each cross-connect and IN/OUT terminal block wire wrap pin	Place the test meter NEG probe on the OUT RN terminal. Touch the POS probe to the cross-connect terminal block OUT TN, IN TN, IN RN, and then the IN/OUT terminal block OUT T, OUT R, IN T and IN R. Observe test meter reading and verify proper condition as shown on <a href="#">Chart 2</a> .
IN TN to each cross-connect and IN/OUT terminal block wire wrap pin	Place the test meter NEG probe on the IN TN terminal. Touch the POS probe to the cross-connect terminal block OUT TN, OUT RN, and then the IN/OUT terminal block OUT T, OUT R, IN T and IN R. Observe test meter reading and verify proper condition as shown on <a href="#">Chart 2</a> .
IN RN to each cross-connect and IN/OUT terminal block wire wrap pin	Place the test meter NEG probe on the IN RN terminal. Touch the POS probe to the cross-connect terminal block OUT TN, OUT RN, IN TN, and then the IN/OUT terminal block OUT T, OUT R, IN T and IN R. Observe test meter reading and verify proper condition as shown on <a href="#">Chart 2</a> .

Chart 2. DSX Jack Assembly Wiring Continuity Test Requirements (Jacks Normal)

JACK CONTACTS NORMAL (TEST CORDS REMOVED)	CROSS-CONNECT TERMINAL BLOCK TERMINAL WIREWRAP PIN				IN/OUT TERMINAL BLOCK WIREWRAP PIN				DSX CHASSIS GROUND
	OUT		IN		OUT		IN		
	TN	RN	TN	RN	T	R	T	R	
#	N	N	N	N	Y	N	N	N	N
N	#	N	N	N	N	Y	N	N	N
N	N	#	N	N	N	N	Y	N	N
N	N	N	#	N	N	N	N	Y	N

Notes: #= Negative Reference Lead (Test Set Neg. Probe). Y = Continuity. N = No Continuity (open). \* Use test cords equipped with alligator clips or equivalent

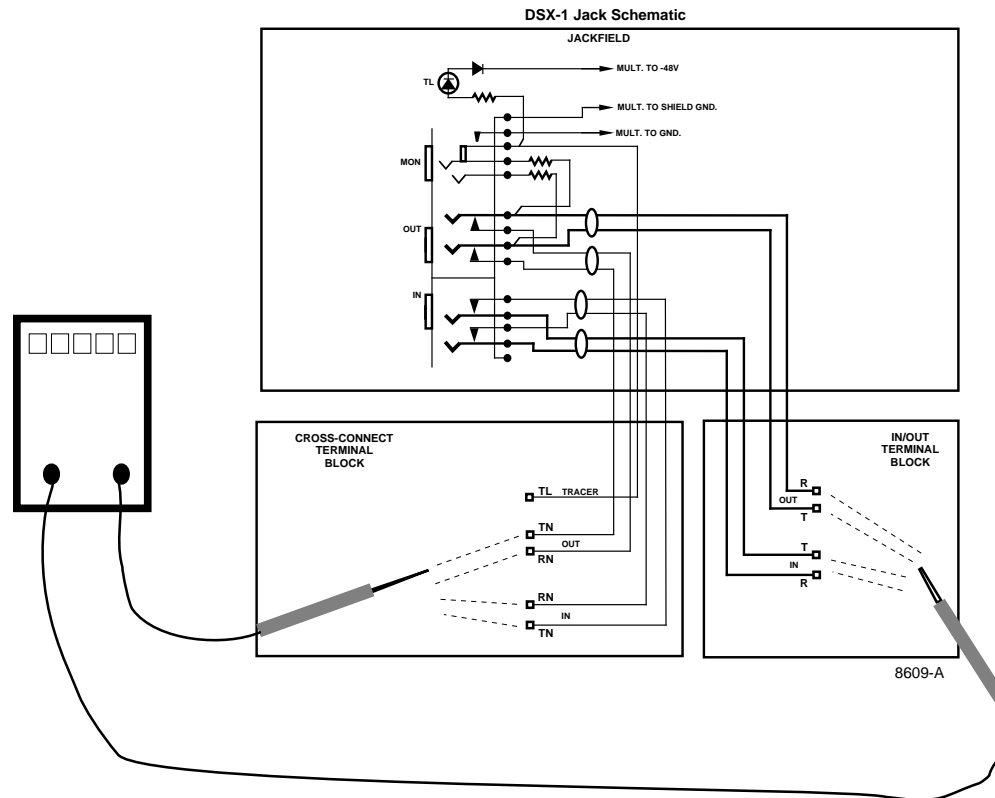

Figure 8. Continuity Test Set Connections (Jacks Normal)



**Telecommunications**

ADC Telecommunications, Inc.  
4900 West 78th Street  
Minneapolis, Minnesota 55435  
FAX: (612) 946-3292  
Toll Free: 1-800-366-3891  
In Minnesota: (612) 938-8080