

# PG-PLUS

## TECHNICAL PRACTICE

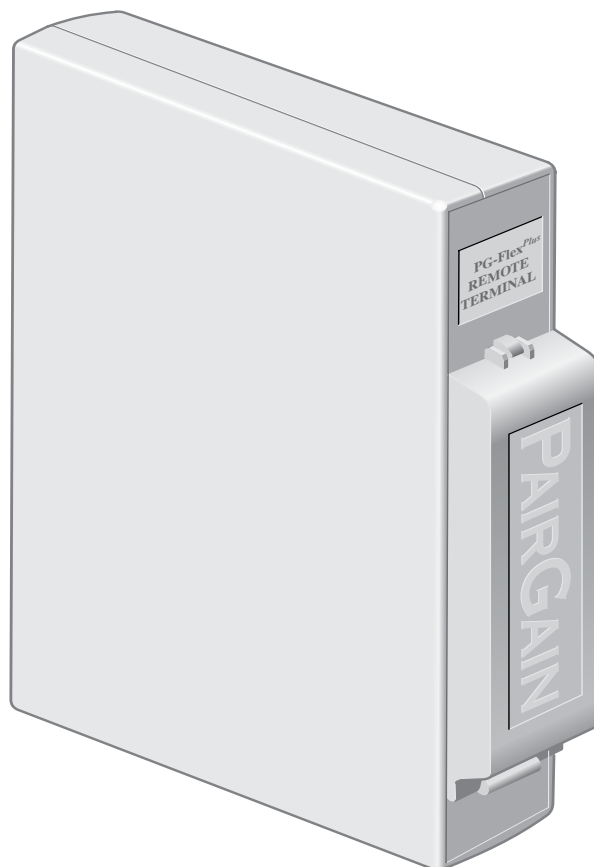

### 6 LS/GS Indoor Remote Terminal Enclosure

Model	List	CLEI Code
PRL-779	1E	S9MSEH0A~~

---

**Revision History of This Practice**

---

<b>Revision</b>	<b>Release Date</b>	<b>Revisions Made</b>
01	December 13, 1999	Initial Release
02	March 17, 2000	Add 4 POTS support information and change reference label graphics
03	February 20, 2002	Release to rebrand document to comply with ADC standards
04	January 6, 2003	Updated Product Support Information

---

**©Copyright 2003 ADC DSL Systems, Inc. All Rights Reserved.**

*ADC is a registered trademark of ADC Telecommunications, Inc. PG-Plus is a registered trademark of ADC DSL Systems, Inc. No right, license, or interest to such trademarks is granted hereunder, and you agree that you shall assert no such right, license, or interest with respect to such trademarks. Other product names mentioned in this document are used for identification purposes only and may be trademarks or registered trademarks of their respective companies.*

*Information contained in this document is company private to ADC DSL Systems, Inc., and shall not be modified, used, copied, reproduced or disclosed in whole or in part without the written consent of ADC.*

*Contents herein are current as of the date of publication. ADC reserves the right to change specifications at any time without notice. Information furnished by ADC is believed to be accurate and reliable. In no event shall ADC be liable for any damages resulting from the loss of data, loss of use, or loss of profits and ADC further disclaims any and all liability for indirect, incidental, special, consequential or other similar damages. This disclaimer of liability applies to all products, publications and services during and after the warranty period.*

## USING THIS PRACTICE

Three types of messages, identified by icons, appear in the text.



**Notes indicate information about special circumstances.**



**Cautions indicate the possibility of equipment damage or the possibility of personal injury.**



**Electrostatic Discharge (ESD) susceptibility symbols indicate that a device or assembly is susceptible to damage from electrostatic discharge. You must wear an antistatic wrist strap connected to the appropriate ground connection prior to performing installation procedures. You must also observe normal ESD precautions when handling electronic equipment. Do not hold electronic plugs by their edges. Do not touch components or circuitry.**

## INSPECTING YOUR SHIPMENT

Upon receipt of the equipment:

- Unpack each container and visually inspect the contents for signs of damage. If the equipment has been damaged in transit, immediately report the extent of damage to the transportation company and to ADC. Order replacement equipment, if necessary.
- Check the packing list to ensure complete and accurate shipment of each listed item. If the shipment is short or irregular, contact ADC as described in [“Returns” on page 15](#). If you must store the equipment for a prolonged period, store the equipment in its original container.



## TABLE OF CONTENTS

<b>Overview</b>	<b>1</b>
Integrated Channel Testing .....	1
Metallic Fallback.....	1
Specifications .....	2
<b>Installation and Turn-up</b>	<b>3</b>
Required Tools and Test Equipment.....	4
Preparing the RT .....	4
Mounting the RT .....	4
Wall Mounting.....	5
Line-up Mounting.....	7
Wiring the RT .....	9
Turn up and Testing .....	12
<b>Fault Isolation</b>	<b>12</b>
COLU Fault Indicators.....	13
Subscriber Reported Faults .....	14
<b>Product Support</b>	<b>15</b>
Technical Support .....	15
Limited Warranty.....	15
Returns .....	15
FCC Class B Compliance .....	17
Modifications .....	17
<b>Acronyms</b>	<b>18</b>



## LIST OF FIGURES

1. Typical PG-Plus Application.....	1
2. Wall Mounting Dimensions .....	5
3. Wall Mounting the RT.....	6
4. Line-up Mounting Dimensions.....	7
5. Line-up Mounting the RT.....	8
6. Reference Label.....	9
7. Opening the Telco Access Door.....	10
8. Attaching the RT Wires.....	11
9. Attaching the FGND, HDSL and Subscriber Line wires .....	11





## LIST OF TABLES

1. COLU LED Fault Isolating .....	13
2. Subscriber Fault Isolating .....	14



# OVERVIEW

The ADC® PRL-779 List 1E provides interfaces for LS/GS POTS subscribers. The PRL-779 supports Loop Start and Ground Start (LS/GS) POTS, allows Tip and Ring polarity reversal for support of Millennium pay phones, and implements TR-08 channel testing. The PRL-779 is a 6 LS/GS Indoor Remote Terminal Enclosure.

A PG-Plus® system provides bidirectional transport of multiple DS0s over a single, unconditioned wire pair using HDSL technology. Using an existing cable, PG-Plus provides for higher bandwidth needs of residential and business customers by providing multiple LS/GS interfaces on a single HDSL twisted-pair wire. [Figure 1](#) shows a minimally configured PG-Plus application that consists of one COT shelf, one COLU, and one RT.

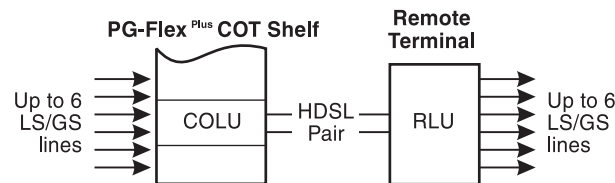

**Figure 1.** Typical PG-Plus Application

Each COLU housed in a COT shelf interfaces with a corresponding RT. LS/GS or digital lines from a CO switching system connect to the COT shelf and are sent by means of the COLU and the HDSL wire pair to an RT. As an example, a 23-inch COT shelf can interface with sixteen different RTs providing up to six LS/GS lines each, for as many as 96 subscriber lines. The COT shelf operates on standard -48 Vdc CO battery and supplies power to the RT, eliminating the need and expense of providing local power at the RT. A PG-Plus system with HDSL transmission and line-powered RTs results in fast, cost-effective solutions to LS/GS deployment over minimal copper facilities.

## INTEGRATED CHANNEL TESTING

The LS/GS RT supports channel testing as described in TR-TSY-000008 and TR-TSY-000465 when the PG-Plus system is configured to interface to a TR-08 compliant digital switch. During the channel test, a sequence of hand-shaking messages and tones are exchanged between the PG-Plus system and the switch, and the LS/GS RT responds by applying the appropriate absorptive ( $600\ \Omega$ ) or reflective ( $0\ \Omega$ ) test terminations to the remote channel under test, thus allowing for both transmission and signalling tests to be performed on that specific channel. The transmission tests verify the transmission parameters, such as channel loss, return loss, and idle channel noise are within the required limits. The signalling tests, that consist of off-hook detection and a ringing test, ensure that the channel can detect and produce the correct signalling states. In addition to the channel testing, the LS/GS RT works in conjunction with the switch to provide subscriber drop testing.

## METALLIC FALLBACK

Metallic fallback provides a direct connection from the CO to subscriber number one under fault conditions. The metallic fallback feature is a provisionable item. You can disable this feature through the user screens.

Service is provided to the subscriber assigned to the LS/GS line in the affected COLU. At the RT, the system exits metallic fallback and attempts to synchronize if either LS/GS number one or the HDSL Tip to Ring pair is shorted for at least 3 seconds, and then released for at least 3 seconds. Otherwise, the COLU checks for the presence of an RT every 5 minutes. If an RT is present, the system begins HDSL synchronization acquisition.

Relays in the COLU and RT under control of the PG-Plus Alarm Unit (PAU) or PG-Plus Management Unit (PMU) provide a path for subscriber drop test and metallic fallback operation. These relays are used to establish a path to channel 1 of the LS/GS RT during fault conditions and to provide for drop testing of the selected subscriber line from the CO location.

## SPECIFICATIONS

### Power

Voltage Safety	A2 compliant per GR-1089-CORE
HDSL Line Input Voltage	+/-135 Vdc Tip to Ring, maximum
HDSL Line Start-up Voltage	+/- 100 Vdc Tip to Ring, minimum
RT Input Power	10.2 Watts typical; 11.2 Watts Tip to Ring, maximum with 4 off-hook, 2 ringing 5 REN

### HDSL

Line Code	2B1Q
Line Rates	
PRL-779	196 K symbols/sec (392 K bps), 261.3 Kbps
Line Reach	
PRL-779	26 AWG (0.4 mm), 12.5 kft (3.81 km) 24 AWG (0.5 mm), 18.0 kft (5.48 km) 22 AWG (0.6 mm), 25.2 kft (7.68 km) 19 AWG (0.9 mm), 37.8 kft (11.5 km)
Maximum Attenuation	
PRL-779	41.6 dB at 98 kHz

### Environment

Temperature	-40 °F to +131 °F (-40 °C to + 55 °C)
Humidity	5% to 95% noncondensing
Altitude	-200 ft. to 13,000 ft. (-60 m to 4,000 m)

### Compliance

Human Safety	UL 1950
Emissions Radiation and Immunity	GR-1089 Core Class B and FCC Part 15 for Class B compliant

### LS/GS Interface

Analog Impedance	600 $\Omega$
RT supervisory range	300 $\Omega$ plus 430 $\Omega$ for handset; or 3.5 kft on 26 AWG; 5.7 kft on 24 AWG; 9.2 kft on 22 AWG
Detection of Loop Open	$\geq 10$ k $\Omega$
Idle State Voltage	-48 V minimum
Loop Current	23 mA minimum
Ring Generation	
PRL-779	Unbalanced Trapezoidal 40 Vrms minimum @ 20 $\pm$ 3 Hz up to 5 REN per line (10 REN total at RT)
Ring Trip	Removed in 200 ms after Loop Closure

**Connectors**

HDSL	Insulation Displacement Contact (IDC) Connector
LS/GS	IDC Connector

**Dimensions**

Height	9 in. (22.9 cm.)
Width	6 in. (15.2 cm.)
Depth	1.8 in. (4.6 cm.)
Weight	2.3 lbs. (1.0 kg.)

## INSTALLATION AND TURN-UP



The PRL-779 List 1E is a listed accessory to be used only with ADC Model PLL-729 or PLL-735 List 1 or equivalent.



Installation and maintenance to be performed by qualified service personnel only. This RT is to be installed in a restricted access location.

To ensure the safety of personnel and equipment, observe the following safety rules:



Be careful when installing or modifying telephone lines. Dangerous voltages can be present. It is unsafe to install telephone wiring during a lightning storm. Always disconnect all telephone lines and power connections before servicing or disassembling this equipment.

All wiring external to the product should follow the local wiring codes.

Always treat the HDSL pair as if it were live with high voltage present. Use caution when installing an HDSL pair that is already connected to a COLU, because dangerous voltages are present on the HDSL pair.

The COLU, unless previously disabled by means of craft provisioning, periodically attempts to power up the RT by applying +/-130 Vdc to the HDSL pair. The COLU also initiates a start-up after a short of at least 3 seconds has been applied to the HDSL pair. The COLU responds with start-up voltage 3 seconds after removal of the short.

The installation of an RT, described in the following sections, involves the following procedures:

- Preparing the RT for wiring
- Mounting the RT
- Wiring the RT
- Turn-up and testing

## REQUIRED TOOLS AND TEST EQUIPMENT

- LS/GS telephone set
- 1/4-inch flat-head screwdriver
- No. 1 Phillips screwdriver
- Insulated-handle 3/8-inch nut driver
- Insulated-handle needlenose pliers
- Insulated-handle wire cutter

## PREPARING THE RT

HDSL and subscriber wiring are threaded through the Insulation Displacement Contact (IDC) connector located on the right-hand side of the RT. Use either the wall mounting or the line-up template provided in the Mounting Kit for the RT wall positioning.

The RT is now prepared for mounting.

## MOUNTING THE RT

The PAU-710 are suitable for mounting on a wall or line-up. Wall mounting is preferable.



**Before setting up the equipment, select a location that will allow sufficient access to wiring connections from the telco access door.**

## Wall Mounting

Use the back panel of the enclosure, or the enclosed hole pattern drawing as a template for marking the locations of mounting holes as shown in [Figure 2](#).

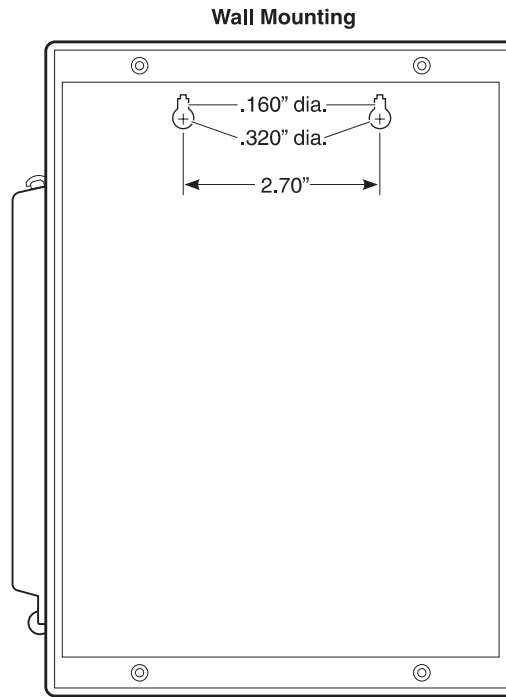

**Figure 2.** *Wall Mounting Dimensions*

Use the two No. 6 x 1-inch wood screws provided in the Mounting Kit to attach the RT to the wall of the restricted access area (see [Figure 3](#)).

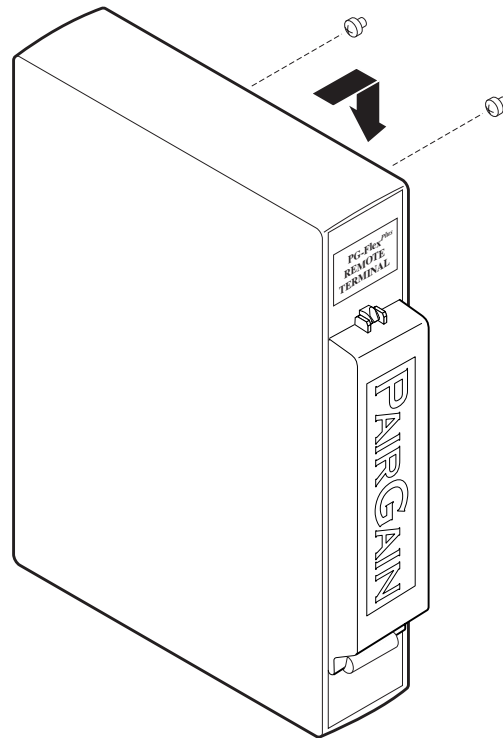
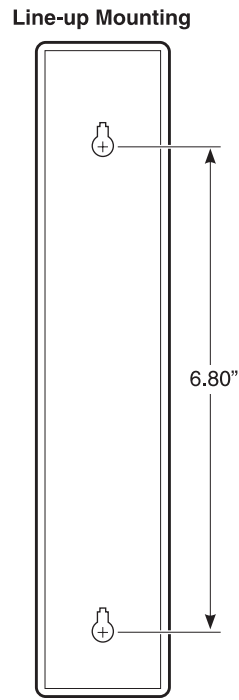

**Figure 3.** Wall Mounting the RT



## Line-up Mounting

Use the back panel of the enclosure, or the enclosed hole pattern drawing as a template for marking the locations of mounting holes as shown in [Figure 4](#).



**Figure 4.** *Line-up Mounting Dimensions*

Use the two No. 6 x 1-inch wood screws provided in the Mounting Kit to attach the RT to the side of the restricted access area (see [Figure 5](#)).

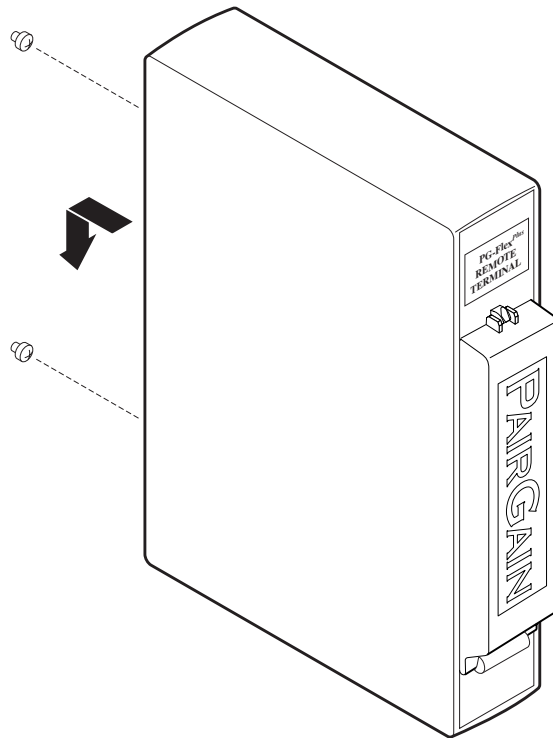

**Figure 5.** *Line-up Mounting the RT*

## WIRING THE RT

Wiring the RT consists of three major steps:

- attaching the frame ground wire
- attaching the HDSL Tip and Ring wires
- attaching the subscriber line wires



**Before setting up the equipment, select a location that will allow sufficient access to wiring connections from the telco access door.**

During installation, refer to the RT Reference label (see [Figure 6](#)) affixed inside the Telco Access door. The Reference label identifies the Frame Ground and HDSL Tip and Ring, and the Subscriber Line wires.



*Figure 6. Reference Label*

## Attaching the Frame Ground, HDSL and Subscriber Line Wires

To install the RT wires, do the following:



**This RT does not provide primary protectors on the HDSL or subscriber pairs. The primary protection for HDSL pairs must be an integral part of the premises wiring. If the subscriber wiring is routed outside of the premises for any reason, then primary protection for subscriber pairs must also be an integral part of the premise wiring.**

- 1 Open the Telco Access door as shown in [Figure 7](#).

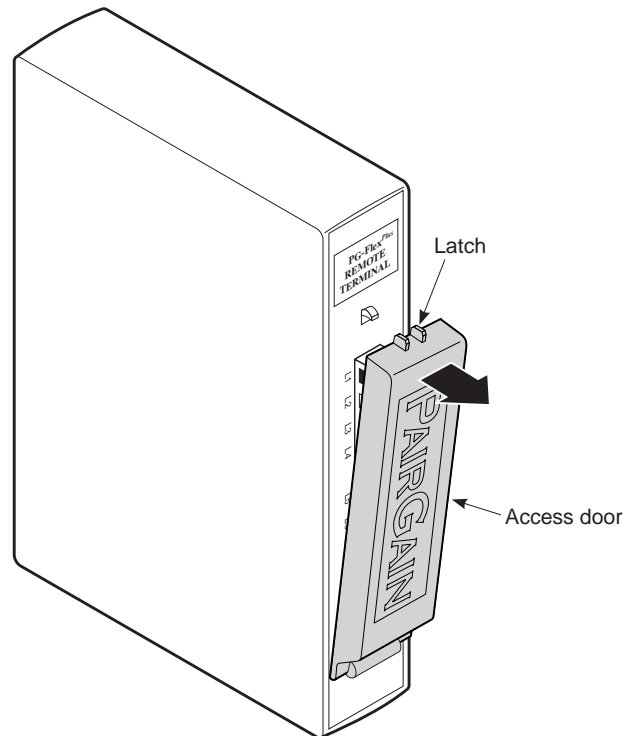

**Figure 7.** *Opening the Telco Access Door*

- 2 Insert the Tip and Ring wires through the hole below the Telco Access door.

- 3 For the FGND and Subscriber Line wires, pivot the IDC connector upward, then insert the wire pair through the tip and ring holes (see [Figure 8](#)). Each wire entry hole accepts one unstripped solid copper wire 22-24 American Wire Gauge (AWG) with a maximum insulation diameter of 1.52 mm.

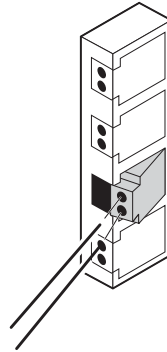

**Figure 8.** Attaching the RT Wires

- 4 Press the IDC connector downward to secure the FGND and Subscriber Line wires (see [Figure 9](#)).

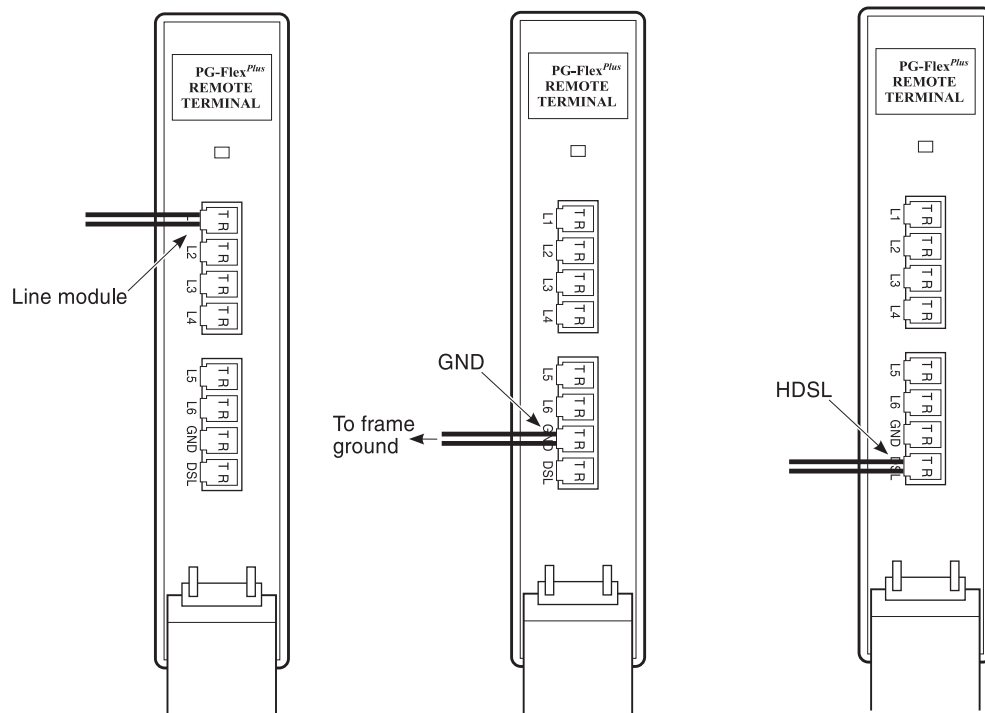

**Figure 9.** Attaching the FGND, HDSL and Subscriber Line wires

- 5 Repeat steps 2 through 4 to attach the HDSL wires.
- 6 Close the Telco Access door.

## TURN UP AND TESTING

To continue the installation of your PRL-779 for readiness:

- 1 Ensure that at least one COLU is installed into the PG-Flex<sup>Plus</sup> COT shelf. Refer to the appropriate COLU Technical Practice for verifying the COLU installation.
- 2 Locate the HDSL Tip and Ring on the protector block or punchdown, apply a short between the HDSL Tip and Ring conductors for at least 3 seconds. Start-up begins in 3 seconds after removal of the short. Within 2 minutes the system should provide dial tone and battery voltage on the subscriber pairs.
- 3 Listen for a dial tone using the customer phone line.
- 4 If dial tone is not heard, then refer to the appropriate COLU Technical Practice for COLU Fault Indicators.

## FAULT ISOLATION

The following sections detail the fault isolation procedures. For sections that indicate a condition such as distance limitation exceeded, refer to “Specifications” on page 2 for the correct values.

## COLU FAULT INDICATORS

At the CO, you can use the VT-100 terminal to initiate a subscriber drop test to determine the cause of any of the following problems. [Table 1](#) provides procedures for isolating faults indicated by the COLU LEDs.

**Table 1.** COLU LED Fault Isolating

LED	Mode	Condition	Procedure
None	On	processor in the COLU stopped	<ol style="list-style-type: none"> <li>1 Remove and re-insert the COLU.</li> <li>2 At the VT-100 interface, go to the COLU Main screen to view the Performance report to verify that no alarms exist. If the COLU Main screen cannot be viewed, a communication error exists, indicating a faulty COLU.</li> <li>3 If the LEDs do not illuminate, replace the COLU.</li> </ol>
Fault	On	indicates an existing alarm condition on the COLU	<ol style="list-style-type: none"> <li>1 At the VT-100 interface, go to the COLU Main screen to view the Performance report to determine the cause of the alarm. Correct the condition, if possible. If the COLU Main screen cannot be viewed, a communication error exists.</li> <li>2 Remove and re-insert the COLU.</li> <li>3 If the communication error still exists, replace the COLU.</li> </ol>
Margin	On	<ul style="list-style-type: none"> <li>• distance limitation exceeded</li> <li>• fault in HDSL line</li> <li>• faulty COLU</li> </ul>	<ol style="list-style-type: none"> <li>1 At the VT-100 interface, go to the COLU Main screen to view the Performance report to verify that no alarms exist.</li> <li>2 Initial installation, check engineering records for distance between COT shelf and RT.</li> <li>3 If existing installation, measure loss of HDSL line to ensure that the maximum attenuation value has not been exceeded.</li> <li>4 Replace the COLU or the RT.</li> </ol>
Margin	Flashing	<ul style="list-style-type: none"> <li>• distance limitation exceeded</li> <li>• fault in HDSL line</li> <li>• faulty RT</li> </ul>	<ol style="list-style-type: none"> <li>1 Initial installation, check engineering records for distance between COT shelf and RT.</li> <li>2 If existing installation, measure loss of HDSL line to ensure that the maximum attenuation value has not been exceeded.</li> <li>3 Replace the COLU or the RT or both.</li> </ol>
SYNC	Off	<ul style="list-style-type: none"> <li>• HDSL line has lost synchronization</li> <li>• distance limitation may have been exceeded</li> <li>• COLU is faulty</li> </ul>	<ol style="list-style-type: none"> <li>1 Initial installation, check engineering records for distance between COT shelf and RT.</li> <li>2 If existing installation, measure loss of HDSL line to ensure that the maximum attenuation value has not been exceeded.</li> <li>3 Replace the COLU or the RT or both.</li> </ol>
PWR	Off	<ul style="list-style-type: none"> <li>• no input power</li> <li>• on-board fuse is blown on COLU</li> </ul>	<ol style="list-style-type: none"> <li>1 Ground fault condition exists.</li> <li>2 Check input COT power at COT shelf backplane with COLU removed.</li> <li>3 If power is present at COT shelf backplane, replace the COLU.</li> </ol>
PWR	Flashing	<ul style="list-style-type: none"> <li>• HDSL line open</li> <li>• an overload exists</li> </ul>	<ol style="list-style-type: none"> <li>1 Check line continuity and resistance.</li> <li>2 COLU power supply or RT may be faulty.</li> </ol>

## SUBSCRIBER REPORTED FAULTS

Use the craft interface to initiate a subscriber drop test to determine the cause of any of the following problems. The subscriber drop test performs Hazardous Potential, Foreign Voltage, Resistive Faults, Receiver Off-Hook, and Ringers Tests. [Table 2](#) provides procedures for isolating faults, based on subscriber reports.

**Table 2.** *Subscriber Fault Isolating*

Conditions	Causes	Procedures
<b>no dial tone, cannot dial</b>	<ul style="list-style-type: none"> <li>Short-circuit or open-circuit</li> <li>faulty COLU or RT</li> </ul>	<ol style="list-style-type: none"> <li>At the CO using the craft interface, select Test menu option, and view the test results. The tests run are for Hazardous Potential, Foreign Voltage, Resistive Fault, and CPE Termination.</li> <li>Check for shorts or opens towards the subscriber or on the customer premise.</li> <li>Lift the jumper in the CO between the CO switch and the COT shelf. If dial tone is present at the switch, replace the COLU.</li> <li>If after replacing the COLU the dial tone is still not present, the fault is in the RT. Replace the RT.</li> </ol>
<b>Phone does not ring</b>	<ul style="list-style-type: none"> <li>high-resistance short on subscriber drop (REN load exceeded, see Specifications)</li> <li>faulty RT or COLU</li> </ul>	<ol style="list-style-type: none"> <li>At the CO, using the craft interface, go to the COLU Main screen to verify the correct operation of the COLU. If you cannot view the COLU Main screen, a communication error exists indicating a faulty COLU. Remove and re-insert the COLU.</li> <li>Go to the Test menu option, and select the desired circuit to test.</li> <li>View the subscriber drop test results. Refer to the Test Submenu section for specific results.</li> <li>Check for ringing on another line terminated on the same RT. If ringing is present on other lines, check for high-resistance shorts on the subscriber drop. If no high resistance shorts, replace the RT.</li> <li>If ringing is not present on another circuit terminated on the RT, lift the jumper between the CO switch and the COT shelf. If ringing is present, replace the COLU. If ringing is not present, the fault is in the switch.</li> </ol>
<b>Phone does not stop ringing</b>	<ul style="list-style-type: none"> <li>faulty subscriber station instrument</li> <li>loop length too long</li> <li>faulty RT</li> </ul>	<ol style="list-style-type: none"> <li>If phone stops ringing when using a butt set at the subscriber location, the subscriber's station internal resistance is too high. Replace phone.</li> <li>If phone does not stop ringing when using a butt set at the subscriber location, one or both of these conditions exist: <ul style="list-style-type: none"> <li>loop length is too long (refer to Specifications)</li> <li>or the RT is faulty</li> </ul> </li> </ol>
<b>Cannot hear, cannot be heard</b>	<ul style="list-style-type: none"> <li>faulty COLU or RT</li> </ul>	<ol style="list-style-type: none"> <li>Lift the jumper in the CO between the CO switch and the COT shelf. <ul style="list-style-type: none"> <li>If audible level is acceptable, replace the COLU or RT</li> <li>otherwise, the problem is in the CO switch</li> </ul> </li> </ol>



# PRODUCT SUPPORT

## TECHNICAL SUPPORT

Technical Assistance is available 24 hours a day, 7 days a week by the contacting Customer Service Engineering group at:

Telephone: 800.366.3891  
The 800 telephone support line is toll-free in the U.S. and Canada.

Email: [wsd\\_support@adc.com](mailto:wsd_support@adc.com)

Knowledge Base: [http://adc.com/Knowledge\\_Base/index.jsp](http://adc.com/Knowledge_Base/index.jsp)

Web: [www.adc.com](http://www.adc.com)

## LIMITED WARRANTY

Product warranty is determined by your service agreement. Refer to the ADC Warranty/Software Handbook for additional information, or contact your sales representative or Customer Service for details.

## RETURNS

To return equipment to ADC:

- 1 Locate the number of the purchase order under which the equipment was purchased. To obtain a return authorization number, you need to provide the original purchase order number to ADC's Return Material Authorization (RMA) Department.
- 2 Call or write ADC's RMA Department to ask for an RMA number and any additional instructions. Use the telephone number, fax number or email address listed below:
  - Telephone: 800.366.3891
  - Email Address: [rma@ADC.com](mailto:rma@ADC.com)
- 3 Include the following information, in writing, along with the equipment you are returning:
  - Company name and address.
  - Contact name and telephone number.
  - The shipping address to which ADC should return the repaired equipment.
  - The original purchase order number.
  - A description of the equipment that includes the model and part number of each unit being returned, as well as the number of units that you are returning.
  - The reason for the return. For example:
    - The equipment needs an ECO/ECN upgrade.
    - The equipment is defective.



**If the equipment is defective, please tell us what you observed just before the equipment malfunctioned. Be as detailed in your description as possible.**

If there is another reason for returning the equipment, please let us know so we can determine how best to help you.

- 4 Pack the equipment in a shipping carton.
- 5 Write ADC's address and the RMA Number you received from the RMA Department clearly on the outside of the carton and return to:

ADC DSL Systems, Inc.  
14352 Franklin Ave.  
Tustin, CA 92780-7013

Attention: **RMA (Number)**



**All shipments are to be returned prepaid. ADC will not accept any collect shipments.**

## FCC CLASS B COMPLIANCE

This equipment has been tested and found to comply with the limits for a Class B digital device, pursuant to part 15 of the FCC Rules. These limits are designed to provide reasonable protection against harmful interference in a residential installation. This equipment generates, uses and can radiate radio frequency energy and, if not installed and used in accordance with the instructions, may cause harmful interference to radio communications. However, there is no guarantee that interference will not occur in a particular installation. If this equipment does cause harmful interference to radio or television reception, which can be determined by turning the equipment off and on, the user is encouraged to try to correct the interference by one or more of the following measures:

- \* Reorient or relocate the receiving antenna.
- \* Increase the separation between the equipment and receiver.
- \* Connect the equipment into an outlet on a circuit different from that to which the receiver is connected.
- \* Consult the dealer or an experienced radio/TV technician for help.

## Modifications

The FCC requires the user to be notified that any changes or modifications made to this device that are not expressly approved by ADC voids the user's warranty.

All wiring external to the product(s) should follow the provisions of the current edition of the National Electrical Code.

# ACRONYMS

<b>AWG</b>	American Wire Gauge
<b>CO</b>	Central Office
<b>COLU</b>	Central Office Line Unit
<b>COT</b>	Central Office Terminal
<b>ESD</b>	Electrostatic Discharge
<b>HDSL</b>	High-bit-rate Digital Subscriber Line
<b>IDC</b>	Insulation Displacement Contact
<b>LED</b>	Light-emitting Diode
<b>LS/GS</b>	Loop Start and Ground Start
<b>MLT</b>	Mechanized Loop Test
<b>PAU</b>	PG-Plus Alarm Unit
<b>PMU</b>	PG-Plus Management Unit
<b>POTS</b>	Plain Old Telephone Service
<b>REN</b>	Ringer Equivalence Number
<b>RMA</b>	Return Materials Authorization
<b>RT</b>	Remote Terminal



---

**World Headquarters:**

ADC Telecommunications, Inc.  
12501 Whitewater Drive  
Minnetonka, Minnesota USA 55343

**For Technical Assistance:**

800.366.3891



1251809

---